



# TOWN OF CAREFREE, ARIZONA

## SPECIFICATIONS AND CONTRACT DOCUMENTS

**Project Number: 2024-100**

### PAVEMENT MAINTENANCE PROJECTS 2023-2024

**TOWN ADMINISTRATOR:** Gary S. Neiss  
480-488-1471

**CONTRACT ADMINISTRATOR:** Mark M. Milstone, P.E.  
480-640-6221

**TOWN ENGINEER:** Mark M. Milstone, P.E.  
8 Sundial Circle  
PO Box 740  
Carefree, AZ 85377  
Email: [Mark@carefree.org](mailto:Mark@carefree.org)

**BID OPENING:** Friday  
07/14/2023  
**TIME:** 9:00 AM MST

**LOCATION:** Town Hall  
8 Sundial Circle  
Carefree, Arizona 85377



# TOWN OF CAREFREE, ARIZONA

## STREETS & RIGHT-OF-WAY DEPARTMENT

### PROJECT SPECIFICATIONS AND BID DOCUMENTS

Project Number: **2024-100**

### **PAVEMENT MAINTENANCE PROJECTS 2023-2024**

- Cape Seal (Slurry Seal on Chip Seal)
- Striping and Pavement Markings

Mayor John Crane

Vice Mayor Cheryl Kroyer

Council Members:

Sheila Amoroso

Vince D'Aliesio

Stephen Hatcher

Michael Johnson

1 Council member is currently vacant

|   |           |
|---|-----------|
| <b>NOTICE INVITING BIDS .....</b>   | <b>3</b>  |
| <b>INFORMATION FOR BIDDERS .....</b>  | <b>4</b>  |
| <b>1. SUBMITTING BIDS .....</b>   | <b>4</b>  |
| <b>2. BONDS REQUIRED .....</b>  | <b>4</b>  |
| <b>3. INTERPRETATIONS, ADDENDA .....</b>                                      | <b>5</b>  |
| <b>4. AWARD/REJECTION OF BIDS .....</b>                                       | <b>5</b>  |
| <b>5. EXECUTION OF CONTRACT .....</b>   | <b>6</b>  |
| <b>6. START AND COMPLETION OF WORK.....</b>                                   | <b>6</b>  |
| <b>7. MEASUREMENT AND PAYMENT .....</b>                                       | <b>6</b>  |
| <b>8. PLANS AND SPECIFICATIONS TO SUCCESSFUL BIDDER .....</b>                 | <b>6</b>  |
| <b>9. CONTRACTOR'S INSURANCE COVERAGE.....</b>                                | <b>6</b>  |
| <b>10. PERMITS .....</b>  | <b>8</b>  |
| <b>11. EXAMINATION OF CONTRACT DOCUMENTS AND SITE .....</b>                   | <b>8</b>  |
| <b>BID FORMS AND BID SCHEDULE .....</b>                                       | <b>10</b> |
| <b>BID FORM.....</b>  | <b>11</b> |
| <b>BID SUBMITTAL .....</b>  | <b>15</b> |
| <b>BID BOND .....</b>   | <b>16</b> |
| <b>GENERAL CONDITIONS.....</b>  | <b>17</b> |
| <b>CRACK SEALING and MANUFACTURER'S RECOMMENDATIONS.....</b>                  | <b>20</b> |
| <b>SLURRY SEAL.....</b>   | <b>22</b> |
| <b>CITY OF PHOENIX SUPPLEMENT AS APPLICABLE TO THE TOWN OF CAREFREE .....</b> | <b>23</b> |
| <b>ASPHALT CONCRETE: .....</b>  | <b>36</b> |
| <b>EXHIBIT A.....</b>   | <b>37</b> |
| <b>EXHIBIT B.....</b>   | <b>38</b> |
| <b>EXHIBIT C.....</b>   | <b>39</b> |
| <b>EXHIBIT D.....</b>   | <b>40</b> |
| <b>CONTRACT FORMS.....</b>  | <b>42</b> |

**NOTICE OF AWARD .....43**

**ACCEPTANCE OF NOTICE: .....44**

**TOWN OF CAREFREE CONTRACTOR AGREEMENT .....45**

**CONTRACTOR AGREEMENT .....45**

**CONTRACT BOND.....53**

**LABOR AND MATERIALS BOND.....55**

**CERTIFICATE OF INSURANCE .....57**

**NOTICE TO PROCED.....57**

**CONTRACTOR'S NOTICE OF FINAL ACCEPTANCE.....59**

**AFFIDAVIT REGARDING SETTLEMENT OF CLAIMS.....60**

**CONTRACTOR'S NOTICE OF FINAL ACCEPTANCE.....59**

**APPENDIX A.....63**

**PROJECT NAME: PAVEMENT MAINTENANCE PROJECTS 2023-2024**

**NOTICE INVITING BIDS**

The proposed work is in the Town of Carefree, Arizona at various locations and consists of furnishing all labor and materials.

**Overview:**

1. Cape Seal (Slurry Seal on Chip Seal)
2. Fog Seal
3. 1-1/2" Mill and Overlay
4. Striping

**SEALED BIDS WILL BE RECEIVED BY THE TOWN UNTIL BUT NO LATER THAN**

9:00 AM MST on Friday JULY 14, 2023, at which time the bids will be open. Each bidder must deliver its bid to the Carefree Town Hall located at 8 Sundial Circle, Carefree, AZ 85377. The documents are available on the Town's website: <https://www.carefree.org/employment-rfp-bids>. The Town will not be responsible for oral instructions or information. In the event questions are received less than four (4) days before the bid opening, a determination will be made by the Town concerning the sending of a written addendum, which may result in the establishment of a new bid opening date.

## **INFORMATION FOR BIDDERS**

### **1. SUBMITTING BIDS**

- 1.1 No bid will be considered unless it is submitted on the bid forms contained herein, fully completed and presented, sealed, in an opaque envelope.
- 1.2 BIDDERS MUST ENTER THEIR NAME AND ADDRESS IN THE UPPER LEFT CORNER OF THE ENVELOPE AND THE PROJECT NUMBER, WITH THE TIME AND DATE OF THE BID OPENING IN THE LOWER LEFT CORNER OF THE ENVELOPE.
- 1.3 Bids received after the time and date specified above will be returned unopened to the bidder. A bid may be withdrawn prior to the time set for opening bids. No bid may be withdrawn for a period of sixty (60) days after the date set for receipt of bids.
- 1.4 Bids accepted by the Town constitute a legally binding offer to contract with the Town in response to this invitation and on the Town of Carefree construction contract.

### **2. BONDS REQUIRED**

- 2.1 Each bid must be accompanied by a certified check or cashier's check made payable to the order of Town of Carefree in the sum of not less than 10% of the total bid, or a bond with sufficient sureties to be approved by the Town in a sum equal to 10% of the total bid and naming the Town of Carefree as obligee. Such security shall be returned to all except the three lowest responsible bidders within twelve (12) days after the opening of bids, and the three (3) remaining securities returned within three (3) days after the bidder to whom the Town Council has awarded the contract has executed the contract.
- 2.2 Bonds in the following amounts will be required at the time of executing the formal contract:
  - 1) Contract (Performance) Bond - one hundred percent (100%) of the contract price.
  - 2) Labor and Materials (Payment) Bond - one hundred percent (100%) of the contract price.
- 2.3 At the time of approval of any additional work by change order, the contractor may be required to provide an additional amount of Contract (Performance) Bond and/or Labor and Materials (Payment) Bond equal to 100% of any resulting contract price increases deemed appropriate by the Contract Administrator or designee.
- 2.4 Performance and Payment Bonds must be provided on statutory forms included in these documents

### **3. INTERPRETATIONS, ADDENDA**

- 3.1 The Town of Carefree will not be responsible for oral instructions or information. In the event questions are received less than four (4) days before the bid opening, a determination will be made by the Town concerning the sending of a written addendum, which may result in the establishment of a new bid opening date.
- 3.2 Should a bidder find an ambiguity, inconsistency or error in the drawings or project manual, or should he be in doubt as to their meaning, he shall at once notify the Contract Administrator in writing, who will prepare a written addendum.
- 3.3 Questions or interpretations shall be directed to the Contract Administrator. Each bidder shall designate a specific individual from their organization to communicate with the Contract Administrator.
- 3.4 Any addenda issued by the Town during the time of bidding are to be included in the bid and will become a part of the contract. Bidders must acknowledge receipt of all addenda on the bid form in the space provided, and failure to do so will result in rejection of a bid.
- 3.5 Addenda will be mailed to each person or firm recorded as having received the bidding documents or will be available wherever the bidding documents are kept.

### **4. AWARD/REJECTION OF BIDS**

If the Town Council decides to make a contract award, it shall award the contract to the lowest responsible bidder whose bid is satisfactory to the Town Council and Contract Administrator.

- 4.1 The Town Council and Contract Administrator reserves the right, as the interest of the Town requires, to reject any or all bids, to waive any informality in bids received, to award a contract by accepting or rejecting any alternate bid(s) (additive or subtractive) and reserves the right to reject the bid(s) of any bidder who has previously failed to perform competently in any contract with the Town, or is not a responsible bidder.
- 4.2 If all bids exceed a cost estimate that has been prepared by the Town to complete the Work, instead of rejecting all bids, the Town Council and/or Contract Administrator may, in its sole discretion, negotiate with the apparent low responsible and responsive bidder for a price reduction and the Town may make an award and enter into a contract with the lowest responsible and responsive bidder for such reduced price.

**5. EXECUTION OF CONTRACT**

The Contractor shall execute the standard construction contract with the Town of Carefree within seven (7) days after receiving the Notice of Award.

**6. START AND COMPLETION OF WORK**

Work shall start as specified within the Notice To Proceed and shall be completed within sixty (60) calendar days after such issuance.

**7. MEASUREMENT AND PAYMENT**

Final payment will be made within forty (40) days after approval of the final invoice by the Town Inspector and a CONTRACTOR'S AFFIDAVIT REGARDING SETTLEMENT OF CLAIMS is received. The above affidavit shall be submitted on forms provided in this document.

**8. PLANS AND SPECIFICATIONS TO SUCCESSFUL BIDDER**

The successful bidder may obtain up to five (5) sets of plans and specifications for this project from the Town, or its designee, at no cost. Additional sets will be furnished at cost.

**9. CONTRACTOR'S INSURANCE COVERAGE**

9.1 Compensation Insurance

The Contractor shall secure and maintain during the life of this contract, Workmen's Compensation Insurance for all his employees at the site of the project, and, in case any of the work is sublet, the Contractor shall require each subcontractor similarly to provide Workmen's Compensation Insurance for his employees unless such employees engaged are covered by the Contractor. In the event any class of employees engaged in the work under this contract at the site of the project is not protected by Workmen's compensation Statute, the Contractor shall provide and similarly shall cause such subcontractor to provide special insurance for the protection of each employee not otherwise protected.

9.2 Public Liability and Property Damage Insurance

The Contractor shall secure and maintain, during the life of this Contract, such public liability and property damage insurance, both general and automobile liability, as shall protect him, any subcontractor performing work under this contract, and the Town of Carefree from all claims for bodily injury, including accidental death, and from all claims for property damage arising from operations under this contract, whether such operations are conducted by himself or by any subcontractor or by anyone directly or indirectly employed by either of them. The Contractor agrees to include the Town of Carefree as an additional insured in all the insurance policies required under this contract and such insurance shall be primary.



- 9.3 The minimum limits required are:
- 1) Workmen's Compensation Insurance shall be secured and maintained in accordance with the Workmen's Compensation Laws of Arizona, as revised.
  - 2) Comprehensive General Liability Insurance, including broad form property damage, premises, operations, independent contractors, contractual, and automobile liability, shall be secured and maintained in an amount not less than two million dollars (\$2,000,000) combined single limit.
  - 3) The General Contractor subletting any part of the work awarded to him shall provide a contingent liability policy in the same amount as provided for in his public liability insurance.

- 9.4 Policy coverage shall include, but shall not be limited to coverage for:
- 1) Damage to underground utilities.
  - 2) Liability assumed in construction agreements and other types of contracts or agreements in effect in connection with the subject insured operations.
  - 3) All owned, hired or non-owned automotive equipment used in connection with the insured operation.

9.5 Certificates and Cancellation

The Contractor shall submit a Certificate of Insurance evidencing the required coverage and limits stated above before beginning the Work, but no later than within ten (10) days of receiving the Notice of Award. Failure to maintain the required insurance coverage in continuous force from this date until final completion and acceptance is a material breach of the contract and constitutes grounds for termination.

Insurance evidenced by this Certificate shall not expire, be cancelled, or materially changed without fifteen (15) days prior written notice to the Town and that statement must appear on the Certificate.

If a policy does expire during the life of the contract, a renewal Certificate of the required coverage must be sent to the Town of Carefree no later than fifteen (15) days prior to the expiration date.

9.6 Indemnification

The Contractor shall defend, indemnify, and hold harmless the Town of Carefree and any jurisdiction or agency issuing permits for any work included in the project, their officers, agents and representatives from all damages, claims or liabilities and expenses, (including attorney fees) costs of suit, and legal expenses of any character or nature brought on account of any injuries or damage sustained by any person or property arising out of the work done in fulfillment of the construction of the improvement under the terms of this agreement, on account of any act of omission by the

Contractor or his agents, or from any claims or amounts arising or recovered under Workmen's Compensation Laws or any other law, by-law, ordinance, or order or decree. If the Contractor fails to provide a defense for the Town or if Contractor fails to acknowledge without reservation its duty to indemnify and hold the Town harmless as provided in this paragraph, the Town may settle any such claims, damages, or liabilities and conclusively bind the Contractor to the terms of any judgment stipulated to as part of the settlement. Nothing in this paragraph shall require the Contractor to indemnify or hold harmless the Town against any liability for loss or damage resulting from the sole negligence of the Town or its agents.

## **10. PERMITS**

Construction Permits shall be obtained from the Town of Carefree at no cost to the Contractor.

- 10.1 During the life of the contract, the Contractor shall secure and maintain State of Arizona and Town of Carefree transaction privilege (sales) tax permits.
- 10.2 The CONTRACTOR shall state his Arizona Contractor's License number and classification as evidence that he is qualified to contract the work as indicated in the specifications and shall keep his Contractor's License in good standing during the life of the contract.

## **11. EXAMINATION OF CONTRACT DOCUMENTS AND SITE**

- 11.1 It is the responsibility of each bidder, before submitting a bid, to:
  - a) examine the contract documents thoroughly,
  - b) visit the site to become familiar with local conditions that may affect cost, progress, performance or furnishing of the work,
  - c) consider federal, state and local laws and regulations that may affect cost, progress, performance or furnishing of the work,
  - d) study and carefully correlate bidder's observations with the contract documents, and
  - e) notify the Contract Administrator of all conflicts, errors, or discrepancies in the contract documents.

The successful bidder shall not be allowed any extra compensation by reason of any matter or thing which a reasonably prudent contractor skilled in the trade could have determined by undertaking any of the foregoing actions.

- 11.2 Information and data reflected in the contract documents with respect to underground facilities at, under, or contiguous to the site is based upon information and data furnished to the Town and engineer by owners of such underground facilities or others. The Town disclaims liability and does not assume responsibility for the accuracy or completeness thereof unless it is expressly provided otherwise in the supplementary conditions. The Contractor shall rely solely on his own information and on information

provided to him under the Arizona Blue Stake Statutes, A.R.S. 400360.21 et seq. for determining the presence and location of underground facilities.

- 11.3 Before submitting a bid, each bidder will, at bidder's own expense, make or obtain any additional examinations, investigations, explorations, tests and studies and obtain any additional information and data which pertain to the physical conditions (surface, subsurface, and underground facilities) at, under, or contiguous to the site or otherwise which may affect cost, progress, performance or furnishing of the work and any and all difficulties or restrictions relating to the performance of the work and which bidder deems necessary to determine its bid for performance with the time, price and other terms and conditions of the contract documents.

Failure of the successful bidder to examine the conditions of the work will not relieve the successful bidder of his obligation to furnish all materials and labor necessary to carry out the provisions of the contract documents and to complete the contemplated work for the consideration set forth in his bid.

- 11.4 On request in advance, the Town will provide each bidder access to the sites to conduct such explorations and tests as are reasonable and as each bidder deems necessary for submission of a bid. Bidder shall indemnify and hold the Town harmless against all claims and liability, which may result therefrom. Bidder shall promptly complete all such explorations and tests, and bidder shall fill all holes, clean up and restore every site to its former condition upon completion of such exploration.
- 11.5 The submission of a bid will constitute an incontrovertible representation by bidder that the bidder has complied with every requirement of the bid documents, that he has carefully examined and understands the contract documents, that he has carefully read and understands the bidding documents, that without exception the bid is premised upon performing and furnishing the work required by the contract documents and such means, methods, techniques, sequences or procedures of construction as may be indicated in or required by the contract documents, and that the contract documents are sufficient in scope and detail to indicate and convey understanding of all terms and conditions for performance and furnishing of the work. The failure of any successful bidder to examine the contract documents or to visit the project sites and to acquaint himself with the conditions relating to the work shall not relieve the successful bidder from the obligations as to his bid in any manner.

## **BID FORMS AND BID SCHEDULE**

**BID FORM**

TOWN OF CAREFREE, ARIZONA

**PROJECT NUMBER:** 2024-100

**PROJECT NAME:** PAVEMENT MAINTENANCE PROJECTS 2023-2024

In compliance with the Advertisement for Bids, by the Town of Carefree, the undersigned bidder:

Having examined the contract documents, work site, and being familiar with the conditions to be met, hereby submits the following bid for all labor, materials, equipment, tools, machinery, and services for completion of the work listed and agrees to execute the contract documents and furnish the required bonds and certificates of insurance for the completion of said work, at the locations and for the prices set forth hereinafter.

Understands that construction of this project shall be in accordance with all applicable Standard Specifications, Details, Uniform Codes, Ordinances, and Regulations as otherwise required by the Project Plans, Supplemental Conditions and General Conditions, Special Provisions and other applicable specifications enclosed and made a part of this document.

Understands that the bid shall be submitted with a bid guarantee or cashier's check or surety bond for an amount not less than ten percent (10%) of the amount bid.

Agrees to execute the contract documents upon receipt of Notice of Award from the Town of Carefree.

Understands that work shall be completed within sixty (60) calendar days, beginning with the day following the starting date specified in the Notice to Proceed. The time allowed for completion of the work includes lead time for all mobilization and for obtaining the necessary material and/or equipment.

The bidder hereby acknowledges receipt of and agrees his bid is based on the following Addenda.

ADDENDUM #\_\_\_\_ DATED: \_\_\_\_\_

ADDENDUM #\_\_\_\_ DATED: \_\_\_\_\_

ADDENDUM #\_\_\_\_ DATED: \_\_\_\_\_

ADDENDUM #\_\_\_\_ DATED: \_\_\_\_\_

The undersigned agrees to construct this project at the prices shown on the Bid Schedule as follows:

**BID SCHEDULE & SUMMARY OF QUANTITIES  
TOWN OF CAREFREE, ARIZONA**

**PROJECT #2024-100**

| <b>SUMMARY OF ROADWAY QUANTITIES PAVEMENT MAINTENANCE PROJECT 2023-2024</b> |             |                 |                  |                  |
|---|-------------|-----------------|------------------|------------------|
| <b>Schedule of Items</b>  | <b>Unit</b> | <b>Quantity</b> | <b>Unit Cost</b> | <b>Extension</b> |
| <b>Crack Seal</b>   | LBS         | 304,799         |                  |                  |
| <b>Cape Seal (Slurry Seal on Chip Seal)</b>                                 | SY          | 291,495         |                  |                  |
| <b>Edge Milling</b>   | LF          | 30,143          |                  |                  |
| <b>Asphalt Patching</b>   | SY          | 241             |                  |                  |
| <b>Fog Seal</b>   | SY          | 15,179          |                  |                  |
| <b>1-1/2 " Mill and Overlay</b>   | SY          | 26,294          |                  |                  |
| <b>Striping</b>   | LS          | 1               |                  |                  |
| <b>Adjustments:</b>   |             |                 |                  |                  |
| <b>Water Valves/Survey Monument</b>   | EA          |                 |                  |                  |
| <b>Manholes</b>   | EA          |                 |                  |                  |
| <b>Traffic Control/Barricading</b>  | LS          | 1               |                  |                  |
| <b>Mobilization</b>   | LS          | 1               |                  |                  |
|   |             |                 | <b>Total</b>     |                  |

Turn Lane-Use Arrow

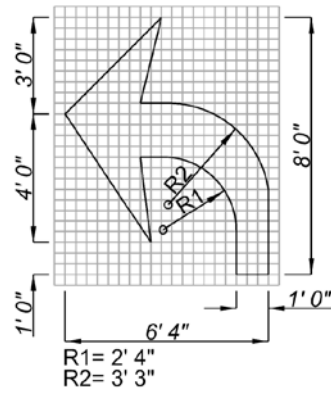

Turn and Through Lane-Use Arrow

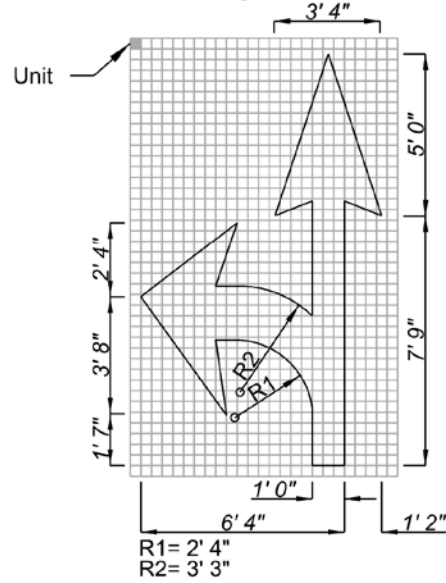

Lane-Reduction Arrow

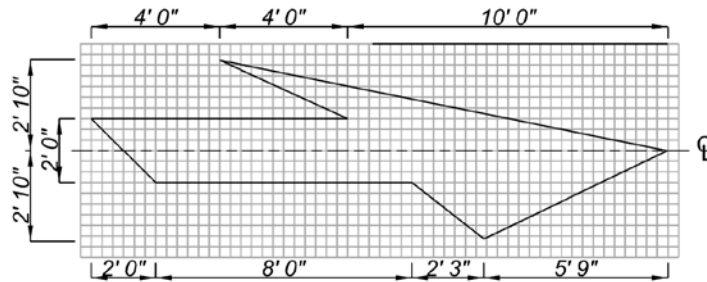

Merging Right to Left

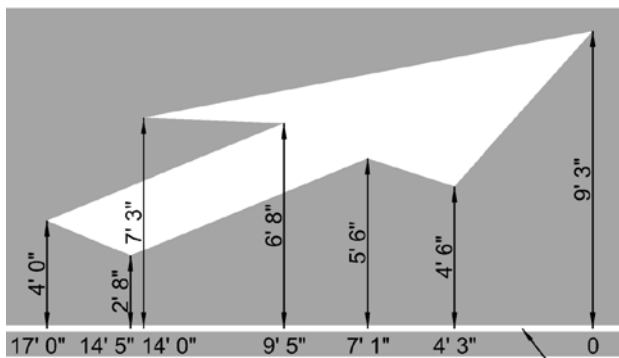

Merging Left to Right

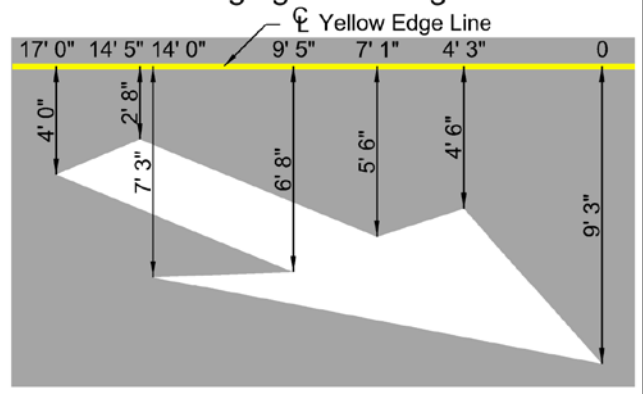

**TOTAL BID OF:**

\_\_\_\_\_ Dollars (\$ x,xxx,xxx.xx).

Amounts shall be shown in both words and figures. In case of discrepancy, the amount shown in words shall govern. Include summation of all three base bid tabs given above.

Only bids responding to all items contained in the proposal will be considered. The contract will be awarded to the responsible bidder with the lowest base bid as per Section 4, INFORMATION FOR BIDDERS.

Contractor's License Number and Classification:

\_\_\_\_\_  
\_\_\_\_\_



**BID SUBMITTAL**  
TOWN OF CAREFREE, ARIZONA

**PROJECT NUMBER:** 2024-100

**PROJECT NAME:** PAVEMENT MAINTENANCE PROJECTS 2023-2024

THIS BID IS SUBMITTED BY \_\_\_\_\_ a corporation organized under the laws of the State of Arizona **or** a partnership consisting of \_\_\_\_\_ **or** an individual trading as \_\_\_\_\_ of the City of \_\_\_\_\_.

By submitting this bid, I/we hereby agree to enter into the Contract included in the bid documents and I/we further agree that this bid incorporates by reference to the same extent as if set forth herein in full all of the terms and conditions contained in said bid documents identified as including the Plans, Project Manuals, General Conditions, Supplemental Conditions, and Addenda, if any.

Respectfully submitted:

FIRM: \_\_\_\_\_

ADDRESS: \_\_\_\_\_  
\_\_\_\_\_

PHONE: \_\_\_\_\_

BY: \_\_\_\_\_  
Officer and Title

IF BIDDER IS AN INDIVIDUAL: \_\_\_\_\_ (SEAL)

Witness: \_\_\_\_\_

\_\_\_\_\_  
Witness' Address

**BID BOND**

KNOW ALL MEN BY THESE PRESENTS: That we \_\_\_\_\_, as Principal, and \_\_\_\_\_, as Surety, are held and firmly bound unto the Town of Carefree in the penal sum of Ten Percent (10%) of Bid Amount, Dollars (\$\_\_\_\_\_) lawful money of the United States of America, to be paid to the order of the Town of Carefree, for which payment, well and truly to be made, we bind ourselves, our successors and assigns, signed with our seals and dated \_\_\_\_\_, 2023. The conditions of the above obligation are such that whereas the Town Council of the Town of Carefree, on the \_\_\_\_ day of \_\_\_\_\_, 2023 did order the following works to be done, to wit:

**PROJECT NUMBER: 2024-100  
PAVEMENT MAINTENANCE PROJECTS 2023-2024**

WHEREAS \_\_\_\_\_, the principal herein in answer to the Notice Inviting Proposals or Bids issued by the Town of Carefree, put in its bid for the making of said improvements.

NOW THEREFORE, if the Obligee accepts the proposal of the Principal and the Principal enters into a contract with the Obligee in accordance with the terms of the proposal and gives the Bonds and Certificates of Insurance as specified in the Standard Specifications with good and sufficient surety for the faithful performance of the contract and for the prompt payment of labor and materials furnished in the prosecution of the contract, or in the event of the failure of the Principal to enter into the contract and give the Bonds and Certificates of Insurance, if the Principal pays to the Obligee the difference not to exceed the penalty of the Bond between the amount specified in the proposal and such larger amount for which the Obligee may in good faith contract with another party to perform the work covered by the proposal then this obligation is void. Otherwise it remains in full force and effect provided, however, that this Bond is executed pursuant to the provisions of Section 34-201, Arizona Revised Statutes, and all liabilities on this Bond shall be determined in accordance with the provisions of the section to the extent as if it were copied at length herein.

ATTEST: \_\_\_\_\_  
PRINCIPAL

BY: \_\_\_\_\_  
ATTORNEY IN FACT

(SEAL)

SURETY AGENCY OF RECORD \_\_\_\_\_

AGENCY ADDRESS \_\_\_\_\_

# GENERAL CONDITIONS AND PROJECT SPECIFICATIONS

## GENERAL CONDITIONS

1. This section is a summary of the project specifications. Additional provisions follow.
2. All work shall be performed in accordance with MAG Uniform Standard Specifications and Details for Public Works Construction (2023 Revision to the 2020 Edition) where applicable, ADOT Signing and Marking Standard Drawings, Supplemental Conditions, if any, General Conditions and Specifications, Town of Carefree Town Code, generally accepted quality workmanship, and other specifications and details contained within the contract documents and the Contractor's bid.
3. **Barricading and Traffic Control**

All barricading and traffic control shall be submitted and approved by the Town of Carefree. All barricading and traffic control shall in accordance with the latest City of Phoenix Traffic Barricade Manual with modifications contained herein and approved by the Contract Administrator.

  - 3.1 Special Barricading: Any special barricading arrays, anywhere on the project, must always be maintained until permanent striping occurs.
  - 3.2 Business Access signage shall be provided at primary access ways to businesses as directed by the Town.
4. **Cape Seal (Slurry Seal on a Chip Seal)**
  - 4.1 Cape Seal locations include the entire pavement width of the subdivision streets as shown or called out elsewhere.
  - 4.2 Square yardage for sections of defective asphalt will vary.
    - 4.2.1 Work shall conform to the 2023 Revision to the 2020 Edition of MAG specifications Section 330 as applicable. The cover material (chips) shall be in accordance with Section 330.2.2.
    - 4.2.2 If possible, an anti-tracking material shall be applied with the chips to reduce or eliminate chip tracking.
    - 4.2.3 The slurry seal shall be a Type II slurry seal in accordance with MAG Specifications Section 321 and Section 715.
5. **Adjust water valves, other utility structures and monuments**
  - 5.1 MAG specifications and provisions provided for in the bid and contract documents shall apply.
  - 5.2 Survey Monument installation shall follow MAG Standard Detail #120 (see Exhibit B).
  - 5.3 Water, sewer, gas or other valve cover adjustments shall follow Phoenix Standard Details #1270 and #1391 and/or 1391-1 (see Exhibit C and Exhibit D) and applicable utility company requirements.
  - 5.4 Scottsdale manholes shall follow Scottsdale Standard Detail #2270 (see Exhibit E). Liberty Utilities sewer manholes shall follow MAG specifications and standard details.

- 5.5 The MH in the WB lanes, west of Airport Drive, shall be reset prior to sealing activities. Additional MH's within the travel lanes on Project II will be reviewed for inclusion of resetting.

## 6. Crack Seal

Crack Seal shall be used throughout the limits of all the roadways. Hot crack seal shall be Crafcoc Polyflex 3 (or approved equal).

## Schedule of Work

- 7.1 Working hours in the Town Center areas shall occur between 8:00 a.m. until 6:00 p.m. Monday through Friday, unless otherwise required by the Contract Administrator.
- 7.2 Working hours in remaining project areas outside the Town Center shall be from 6:00 a.m. until 6:00 p.m. Monday through Friday, unless otherwise required by the Contract Administrator.

## Striping and Pavement Markers

- 9.1 Procedures shall meet the current edition of ADOT Standard Specifications for Road and Bridge Construction 2008 (or latest edition), including but not limited to Section 704, ADOT Signing & Marking Standard Drawings, and other applicable sections.
- 9.2 Shall be provided in the approximate quantities shown on the Summary of Quantities and specifications and Exhibit "A". Actual quantities may vary.
- 9.3 The Contractor shall prepare and submit as-built drawings showing measurements of all striping and markers.
- 9.4 The finished pavement marking lines shall have well defined edges and complete pavement surface coverage. Additionally, the lines shall be free from waviness and open spots where the pavement surface shows through.
- 9.5 The striping process shall produce a clean, smooth, even coverage line with no overspray or puddling.
- 9.6 Contractor shall correct any unsatisfactory performance condition at the contractor's expense.
- 9.7 Temporary Striping: Temporary striping shall be completed as soon as practicable within seventy-two (72) hours of completion of asphalt overlays and/or preservative seal coat, as approved by the Town. Special emphasis shall be given at turn lanes and lane closures on Cave Creek Road.
- 9.8 Permanent Striping: Permanent striping shall match existing striping and be completed a minimum thirty (30) days after application of asphalt overlays and/or preservative seal coats, as authorized by the Contract Administrator.
  - 9.8.1 Lines shall be extruded Thermoplastic specified in ADOT Section 704-2.02 at a thickness of 0.090 inches.
  - 9.8.2 Glass beads shall be included in the Thermoplastic and distributed over the striping after application in conformance with ADOT Sections 704-2.02(A), and 704.3.02(G).
  - 9.8.3 Pavement messages and arrows shall be installed using preformed plastic

pavement marking materials and shall meet ADOT section 704.2.01 and the following product, or approved equivalent:

3M™ Stamark™ Tape Series 270 ES

9.8.4 All materials shall be applied per the manufacturers' recommendations and application requirements and specifications.

9.9 Raised Pavement Markers

9.9.1 The Contractor is responsible for removing and replacing all types of existing raised pavement markers with like kind within the work areas.

9.9.2 Quantities shown on the bid documents and Contractor Agreement are estimates; final quantities shall be determined in the field.

**Staging Area**

The contractor can use N. Windmill Road as a staging area.

# PROJECT SPECIFICATIONS

## CRACK SEALING and MANUFACTURER'S RECOMMENDATIONS

### 1. **Materials: Crafcro Polyflex 3 or approved equivalent)**

- 1.1 The Crack Sealant shall be a hot elastomeric asphalt sealant, which is formulated specifically to be a stiff, non-tracking, yet flexible sealant, which is specifically suited for areas subject to pedestrian, slow moving vehicle traffic, and for the local temperature conditions.
- 1.2 The Crack Sealant shall be CRAFCO brand or prior approved equivalent. An equivalent shall meet or exceed ASTM D 1190 and shall have a softening point of not less than 210 degrees Fahrenheit and a viscosity of greater than 2500 cps. An application for equal material must be submitted for approval 10 working days prior to the bid opening.
- 1.3 The Contract Administrator may take samples of materials to an independent laboratory for testing, or onsite inspection for application.

### 2. **Preparation**

- 2.1 Prior to crack sealing, all qualifying cracks shall be cleaned by blowing out with compressed air (at least 80 CFM) until clean. In any areas where weeds are present, the weeds shall be removed, the crack cleaned and then a herbicide (sterilant) will be applied into the crack.

### 3. **Application**

- 3.1 The sealant shall be heated to at least 350 degrees Fahrenheit when applied but not to exceed 400 degrees Fahrenheit, or manufacturer's recommendations. Do not apply when the ambient temperature is less than 40 degrees Fahrenheit.
- 3.2 If pavement is damp or if rain or water has been on the asphalt within the last 48 hours, the cracks can be cleaned out using a "Hot Lance" to clean and completely dry cracks before the crack sealant is applied. However, if the Contractor does not have sufficient verifiable experience using this piece of equipment, the project should be postponed until the cracks have ample time to dry.
- 3.3 A) Cracks of  $\frac{1}{4}$  inch width or more shall be thoroughly cleaned in conformance with manufacturer's specifications and B-1 and C-2 above. Cracks  $\frac{1}{3}$  inch wide or more shall be filled using "Hot Pour" crack sealant. In addition, only a majority of concentrated cracks between  $\frac{1}{4}$  inch wide and  $\frac{1}{2}$  inch wide shall be sealed as determined by the Contract Administrator.  
  
B) Crack sealant shall be applied to the edges of all pavements.
- 3.4 All cracks shall be slightly overfilled and then leveled with a squeegee leaving an even approximately 2- inch band on both sides of the sealed crack and shall not

exceed an average height of 1/8 inch above the pavement. Should the local temperatures stay high enough to leave the crack sealant tacky and increase the possibility of pick up by foot or tire traffic, the crack sealant shall have a blotter material applied over it.

- 3.5 Allow crack sealer to cure at least 2 - 4 hours before applying any top coat including a seal coating, a slurry seals or an overlay.
- 3.6 Crack sealing shall be performed before any seal coating, slurry sealing, or overlays are applied.

#### **4. Conflicts**

In the event of any conflicts concerning specifications and procedures, the manufacturers and MAG specifications shall be the base line for any resolution, as determined by the Town.

## Slurry Seal

### 1. Description

The slurry seal shall be a Type II Slurry Seal in accordance with MAG specifications. The Slurry Seal shall be placed in 1 coat along the entire street. The slurry seal shall be a minimum of 15 lbs/SY and shall include an additive of 4% latex. The application shall be in accordance with the manufacturer's recommendations and shall contain sand.

The slurry seal shall be rolled with one pneumatic tired 12 Ton roller for a minimum of three passes.

All striping and/or stop bars shall be repainted to match existing conditions.

### 2. Conflicts

In the event of any conflicts concerning specifications and procedures, the manufacturers and MAG specifications shall be the base line for any resolution, as determined by the Town.



## CITY OF PHOENIX SUPPLEMENT AS APPLICABLE TO THE TOWN OF CAREFREE

### **\*\*SPECIAL PROVISIONS AS APPLICABLE TO THE TOWN OF CAREFREE, ARIZONA\*\***

When reference is made to the "Engineer" the Contractor shall contact the Town Engineer for further coordination.

#### **1 TRAFFIC CONTROL**

Add the following to City of Phoenix Supplement to MAG, Subsection 401.11,

Payment: Payment for traffic control will be on a lump sum basis for Traffic Control Devices.

#### **2 TRAFFIC REGULATIONS**

A. The following shall be considered arterial/collector streets:

All streets listed "Arterial" or "Collector" in the Town of Carefree Circulation Element.

B. All traffic and/or traffic control devices on this project shall be provided, maintained and/or controlled as specified in the City of Phoenix Traffic Barricade Manual, latest revision.

C. Permission to restrict Town streets, sidewalks and alleys (street closure permits) shall be requested as specified in Chapter 2 of the Traffic Barricade Manual, latest revision.

D. Unless otherwise provided for in the following "Special Traffic Regulations", all traffic on this project shall be regulated as specified in Chapter 2 of the Traffic Barricade Manual, latest revision.

E. No deviation to the "Special Traffic Regulations" will be allowed or implemented unless submitted to the Contract Administrator for review and approval two (2) weeks prior to proposed work.

#### **3 SPECIAL TRAFFIC REGULATIONS**

##### **A. ALL LOCAL STREETS ON THIS PROJECT**

The Contractor can only close one lane, in each direction, on Cave Creek Road at a time. No work will be allowed on residential streets between the hours of 6:00 a.m. and 6:00 p.m. weekdays or on weekends and Town observed holidays. No weekend work will be allowed unless approved by the Contract Administrator.

Arterial and collector streets on this project can be reduced as shown during the times indicated when construction requires:

Two lanes (one each way) 6:00 a.m. to 7:00 p.m. weeknights.

Two lanes (one each way) 8:00 a.m. to 4:00 p.m. weekdays.

During other times, all lanes and left-turn lanes shall be maintained open to through traffic.

**NOTE: ANY TOTAL ROAD CLOSURE WILL BE ALLOWED WITH A PROPER TRAFFIC CONTROL PLAN SHOWING EFFICIENT DETOURS ON RESIDENTIAL STREETS AS APPROVED BY THE ENGINEER.**

**B. STREET CLOSURE PERMIT**

The Contractor shall notify the Contract Administrator and shall also obtain a street closure permit from the Town of Carefree 48 hours prior to any street restriction.

**C. CITIZEN NOTIFICATION**

Contractor shall notify all residents, business or schools, by handbill **no later than 48 hours** and no earlier than 1 week prior to any street restriction that will affect access to their property. The notification will include the statements that A) on-street parking will not be permitted during the affected times. B) all refuse containers should be on the street by 5:30 a.m. on normal collection days to assure pick-up during the construction process. The handbill shall be submitted to the Engineer for review prior to use. The Contractor shall re-notify all areas where work was not performed as scheduled. Any costs associated with notification or re-notification shall be considered incidental to the project.

For emergency notification the handbill will include:

- \* Contractors name, address and phone number.
- \* Project supervisory staff name and phone number.
- \* Contract Administrator name and office phone number.
- \* Description of project.
- \* Dates and times affected for each phase of construction.
- \* Limits of construction.

The Contractor shall notify property owners by handbill at least two weeks in advance at the locations where tree trimming is needed.

**D. REMOVAL OF VEHICLES**

Contractor will be responsible for removal, safe storage and placement back on street of vehicles left on the street that are in conflict with the operation. The Contractor shall also be responsible for posting **NO PARKING** signs. This work shall be included in the cost of Traffic Control. A police officer shall be present any time a vehicle is moved from the street.

**E. RESIDENTIAL ACCESS**

The Contractor shall maintain access to all streets, access roads, driveways, alleys and parking lots. Should it be necessary to close the access to private property, driveway or alley entrance, the closure must be for as short a time as possible and

be restored as soon as possible. The Contractor shall notify affected residents 48 hours prior to any restrictions which may affect access to their property.

If primary access cannot be restored, the Contractor will provide an alternate which will be pre-determined with the residents prior to any restrictions being done. No two adjacent streets shall be closed at the same time. The Contractor shall maintain a high level of access to residential and service vehicles at all times.

**F. PEDESTRIAN ACCESS REQUIREMENT**

The Contractor shall maintain open all sidewalks on this project in a safe manner. In high pedestrian use areas, the Contract Administrator may request alternate walkway routes posted.

**G. SPECIAL SCHOOL ACCESS REQUIREMENT**

Contractor shall maintain streets open to school bus access during all hours of school use. Contractor shall coordinate any access restrictions with the school administrator 72 hours prior to any restrictions and restore access as soon as possible.

**H. FLAGGING OF TRAFFIC**

No flagging of traffic will be permitted during the peak traffic hours of 6:30 a.m. to 8:30 a.m. and 4:00 p.m. to 6:00 p.m. weekdays. Intermittent flagging will be allowed from 8:30 a.m. to 4:00 p.m. to facilitate large construction vehicles.

**I. TRAFFIC CONTROL AND SAFETY**

At the time of the Pre-Construction conference, the Contractor shall designate an employee, other than the Project Superintendent, who is well qualified and experienced in construction traffic control and safety, to be available on the project site during all periods of construction to coordinate and maintain safe barricading whenever construction restricts traffic.

This individual shall be authorized to receive and fulfill instructions from the Contract Administrator and shall supervise and direct traffic control. Instructions and information given by the Contract Administrator to this individual shall be considered as having been given to the Contractor.

**Notification Signs**

The Contractor shall supply adequate notification signs for purposes of informing the public concerning the milling and overlay operations and such dates of construction and times of day as required in the latest Traffic Barricade Manual and Manual on Uniform Traffic Control Devices.

These notification signs shall be needed on all of the streets being worked on and must be posted 72 hours prior to construction operations (for Monday's work, signs shall be up by 6:00 a.m. the Friday before). Signs shall be 6' x 8' with orange background with black legend. Wordage shall be as follows:

(Street Name)  
RESTRICTED FOR WORK OPERATIONS  
(From Street) TO (To Street)  
(Weekdays/Weekends):(Time)A.M. TO (Time)P.M.  
SCHEDULED FOR (Month/Days)  
USE ALTERNATIVE ROUTE!

The cost for notification signs shall be included in the cost for Traffic Control Devices, to include all work and costs for the installation, maintenance, and removal of the signs.

**J. TRAFFIC CONTROL PLAN**

Upon request from the Engineer, the Contractor shall submit a traffic control plan for approval showing placement of all traffic control devices, including all conflicting signs to be covered/removed or relocated or other features that may conflict with the placement of temporary signage.

**K. POLICE OFFICER REQUIREMENTS**

The Contractor shall provide an off-duty police officer to assist with traffic control as needed during operations restricting the street. The off-duty officer shall also give the Contractor the authority to remove vehicles in conflict with the construction. No payment for a Police Officer will be made but said price shall be included in the Lump Sum bid price for Traffic Control/Barricading.

**L. POLICE, HOSPITAL, FIRE STATION, AND CHURCH ACCESS REQUIREMENTS**

Contractor shall maintain a high degree of access to these facilities located on streets under construction at all times. Contractor shall coordinate any access restrictions with the facilities 72 hours prior to construction.

**M. SPECIAL EVENTS**

If there are special events scheduled to take place during the construction of this project, the Contractor shall coordinate these events with his construction schedule.

**N. ITEM ADJUSTMENTS**

All work on item adjustments shall be in one lane in the same day per street. Work shall not proceed to other lanes until previous lane work is complete.

**O. LOCAL STREET ACCESS**

Local access shall be maintained at all times. Local access shall not be used for through traffic, equipment parking, material storage or to stockpile spoil material.

**P. SPECIAL ACCESS REQUIREMENTS**

Contractor shall maintain local business access at all times and will notify businesses 72 hours in advance of any restrictions which will affect their access. Contractor will restore access as soon as possible. If primary access cannot be restored, Contractor will provide an alternative which will be pre-determined with the business prior to any restrictions being done.

**Q. REFUSE COLLECTION ACCESS**

Any time project construction requires the closure or disruption of traffic in any roadway, alley, or refuse collection easement such that normal refuse collection will be interrupted, the Contractor shall, prior to causing such closure or disruption, make arrangements with the local private sanitation companies operating in the area in order that refuse collection service can be maintained. The Contract Administrator shall be notified of the arrangements made.

**R. SEQUENCE OF WORK**

a) Sequence of work shall be such as to comply with Special Traffic Regulations and the following milling requirements:

The chip sealing process shall not precede more than one quarter-section ahead of the sweeping operation, except that in no case will the chip sealing operation proceed more than 2-1/2 days ahead of the paving operation, including weekends and holidays. A non-tracking additive will be used in the chip sealing process to reduce or eliminate loose chips during this phase of the operations. The Contract Administrator shall have the final decision in determining the time period between milling operations and paving operations.

b) The sequence of work shall be approved by the Town.

**S. PERMITTING**

The contractor shall be required to obtain all the required permits for this project including, but not limited to, dust control, MS4, SWPPP, and all other applicable permits.

**4 GENERAL REQUIREMENTS**

**A. SCOPE OF WORK**

The Chip Sealing portion of this project shall be used on all roadway sections in accordance with MAG specifications. The work shall consist of placing and rolling the chips with a non-tracking additive on all streets listed in these specifications or as directed by the Contract Administrator. Subsequent to and as soon as possible after the chip placement, the contractor shall apply the slurry seal.

Application and testing will be in accordance with MAG Standard Specifications section 321 and the specifications herein. For estimating purposes, the percent of

asphalt binder in the modified asphalt concrete mix shall be **as** detailed in the EVAC specifications in Appendix A.

The apparent low bidder shall submit the name of the hot mix supplier and a description of the materials to the Engineer. The Contractor will provide a Job Mix Formula with aggregate gradation target bands. The Contractor will also provide the binder target. Two weeks prior to construction, the Contractor shall submit 3 (three) gallons of the modified asphalt binder and sufficient aggregate for a mix design to be performed in accordance with ASTM-D1559. The results of the mix design shall be utilized to establish the target values for the job mix formula. Binder that does not conform to the EVAC Specs will not be utilized on the project. The use of diesel, silicon, or other admixtures will not be allowed without the prior approval of the Engineer.

The Contractor will place the compacted overlay, from gutter lip to gutter lip, to ¼-inch above the existing gutter lip, where applicable. If no gutter line or curb and gutter exists, the slurry seal overlay shall be applied to the edge of pavement. The overlay shall be feathered as necessary at catch basins to provide drainage and driving comfort. Compaction, rolling, and finishing the new surface course shall be in accordance with MAG section 321 and the specifications herein.

The existing drainage of the roadway shall be preserved or improved. Care will be taken to ensure that existing asphalt valley gutters are replaced to the proper grade. Questions regarding drainage conditions and requirements will be directed to the Engineer through the Contract Administrator.

The Contractor is responsible for chip sealing and slurry sealing as well as cleaning, tack coat, overlaying and post-sweeping the streets in the project. The Contractor shall clean all pavement debris caused during chip sealing and slurry sealing operations before moving the paving operation to the next roadway section.

After installation of the overlay course, all necessary frame and cover adjustments for manholes, valves, survey monuments, sewer clean-outs, etc., shall be completed by the Contractor within the given segments being surfaced.

Any benchmarks or survey monuments disturbed by the Contractor shall be re-established. The Contractor shall replace in kind survey monument frames and covers damaged during construction at the Contractor's expense.

**B. Test Strip**

On the first day of construction, the first 100 tons of chip seal shall be placed as a test strip. This test strip will be used to establish a rolling pattern for compaction, calibration for densities, and to verify mix design. Construction will not proceed until the rolling pattern for compaction has been accepted by the Engineer.

**C. Power Broom**

The equipment used by the Contractor shall include a power pick-up broom, for both the chip sealing and slurry sealing operation, on the job site at all times during the surface operation to assure clean joints and to maintain a clean street prior to overlay or other work. If the Contract Administrator deems it necessary to maintain clean and safe streets during and after sealing operations, up to two additional power pick-up brooms may be required. Any costs associated with this work shall be considered included in the cost of the overlay.

**D. Measurement and Payment**

Measurement and payment for all pay items in the Bid Proposal shall be as indicated in the applicable Standard Specification, City of Phoenix Supplement, Special Provisions, the Bid Proposal Sheet and as indicated herein.

1. Traffic Control

Payment for Traffic Control will be on a lump sum basis.

2. Revise MAG 321.13 third paragraph, first sentence to read:

"No payment will be made for any overrun in quantity of modified asphalt concrete in excess of 25 percent based on actual field measurement of the area covered per quarter section, the specified design thickness, and the unit weight of mix (pounds per cubic foot) per the approved mix design."

3. Final Acceptance

The final acceptance date for this project and the commencement of the 45-day time period for final payment as set forth in MAG 109.7, will begin upon completion of:

- 1) All remaining punch list items.
- 2) Resolution of any and all claims.
- 3) Provision of quantity verifications.
- 4) Agreement on final quantities.

Please note the 45-day time period does not begin until all of the items listed herein are resolved.

**E. Summary of Quantities Sheet**

The measurements indicated on the summary of quantities sheet are estimated and are for the Contractor's convenience only. Actual field measurements shall be verified by the Contractor. Any costs associated with field measurements shall be considered incidental to the contract.

**F. Night Work**

Night work will not be permitted unless approved by the Contract Administrator in writing.

**G. Weekends and Town approved Holidays**

Work will not be permitted on weekends and Town designated Holidays unless approved by the Contract Administrator.

**5 MAG SECTION 105.6 - COOPERATION WITH UTILITIES:**  
**Modify the Standard Specifications to add the following:**

The Contractor shall be the Blue Stake field locator and perform all requirements as prescribed in A.R.S. 40-360.21 through .29, for all underground facilities that have been installed by him on the current project, until the project is accepted.

At least two (2) working days prior to commencing excavation, the Contractor shall call BLUE STAKE CENTER, between the hours of 7:00 a.m. and 4:30 p.m., Monday through Friday for information relative to the location of buried utilities.

The Contractor will be responsible for the tie-out of all water valves, manholes, etc., for location and adjustment after the overlay except for survey monuments. The method used shall be approved by the Contract Administrator prior to starting work.

Prior to paving, the Contractor shall provide to the Contract Administrator, a map clearly locating all manholes, valves, etc. to be adjusted after paving.

The Contractor shall adjust all existing frames and covers in the project area to the new pavement elevation with the possible exception of utility company manholes. The Contractor will coordinate with the Contract Administrator and with representatives of the various utilities regarding the adjustment and inspection of their manholes. Utility companies' specifications shall be adhered to during adjustment. The Contractor shall be responsible for obtaining any additional specification requirements from the utility companies.

The Contractor shall contact the following utility companies prior to the start of construction.

|  |   |
|--|---|
| <u>Carefree Water Company</u>          | Greg Crossman: 480-488-9100<br>Greg@carefreewaterco.com   |
| <u>Cave Creek Water</u>                | Shawn Kruzweisner: 480-488-6618<br><a href="mailto:skruzweisner@cavcreekaz.gov">skruzweisner@cavcreekaz.gov</a> |
| <u>Liberty Utilities (Sewer)</u>       | 480-285-7729  |
| <u>Arizona Public Services Company</u> | 602-493-4225  |
| <u>Southwest Gas Corp.</u>             | ELM Locating Dispatch: 623-780-3350   |
| <u>Cox Communication Company</u>       | USIC Dispatch Center: 800-778-9140  |
| <u>Century Link</u>                    | USIC Dispatch Center: 800-778-9140  |



### **Cooperation Between Contractors and Utility Companies.**

Other Contractors and utility companies are expected to be working in or near the areas of this contract. It shall be the responsibility of the Contractor to coordinate the work to ensure a smooth and orderly sequence of construction. Any costs associated with this coordination shall be considered incidental to the contract.

## **6 MAG SECTION 321 - ASPHALT CONCRETE PAVEMENT: Modify the Standard Specifications to add the following:**

### **A. ASPHALT CONCRETE OVERLAY SURFACE COURSE**

Modified asphalt slurry seal surface course will be applied to seal the roadway for the entire project. a **MINIMUM** two (2)-inch compacted modified asphalt concrete will be applied on all streets as specified in the Summary of Quantities unless otherwise directed.

Application and testing will be in accordance with MAG 321 and 322.

The handling of asphaltic concrete shall at all times be such as to minimize segregation. Any asphaltic concrete which displays segregation shall be removed and replaced.

Before the slurry seal is placed, the surface to be sealed shall be cleaned of all objectionable material and tacked with a light coat of emulsified asphalt cement. The cleaning of the surface, the tacking of the surface, and the amount and grade of emulsified asphalt cement used shall be as directed by and acceptable to the Contract Administrator.

A light coat of asphalt cement shall be applied as directed to edges or vertical surfaces against which the slurry seal is to be placed. The surface upon which the slurry seal is to be placed shall be prepared in accordance with the applicable requirement for the material involved and maintained in a smooth and firm condition until placement. The slurry seal shall not be placed on a frozen or excessively wet surface.

All slurry seal shall be placed either as a leveling course or as a surfacing course. Leveling courses are defined as courses placed for the primary purpose of raising an existing paved or unpaved surface to a smooth plane. Surfacing courses are defined as courses placed to serve either as the traffic surface or as a surface upon which a finishing course or seal coat is to be placed.

Thickness of leveling and surfacing courses will be as directed by the Engineer. No change in thickness will be allowed without the written approval of the Engineer.

**B. The tack coat shall be per MAG 329 unless directed otherwise by the Contract Administrator.**

## **7 SECTION 345 - ADJUSTING FRAMES, COVERS, VALVE BOXES, AND WATER METER BOXES: Modify the Standard Specifications to add the following:**

### **A. ADJUSTMENT OF EXISTING MANHOLES, VALVES AND CLEANING COVERS**

The Contractor will be responsible for the tie-out of all water valves, manholes, etc., for location and adjustment after the overlay except for survey monuments. The method used shall be approved by the Contract Administrator prior to starting work.

Prior to paving, the Contractor shall provide to the Contract Administrator, a map clearly locating all manholes, valves, etc. to be adjusted after paving.

The Contractor shall adjust all existing frames and covers in the project area to the new pavement elevation with the possible exception of utility company manholes. Contractor shall keep rings and covers matched and shall replace them to their original locations.

The Contractor shall remove all asphalt material and aggregate from this or prior work from all metal covers encountered within the limits of this project. The method for removal of this material must be approved by the Contract Administrator prior to its being used. This work shall be completed prior to adjusting the frame. Debris shall not be permitted to enter sanitary or storm sewer conduits. All loose material and debris shall be removed from the excavation and the interiors of structures prior to resetting frames.

The utility adjusting Contractor shall comply with the OSHA standards and regulations regarding confined space entry.

Missing covers will be supplied by the affected utility and shall be replaced by the Contractor. Cost shall be incidental to the project and the responsibility of the Contractor.

The frames and covers of manholes shall be adjusted according to MAG Standard Detail 422 and the special provisions herein, except that the concrete collar shall extend up to finished grade. Water valve, survey monument and sewer clean out frames and covers shall be installed in accordance with City of Phoenix Supplement Standard Details P1270, P1391 (**with the exception that debris cap is not required in this project document**) and the special provisions herein. Prior to pouring the concrete and setting manhole frames, the edge of the excavation shall be rolled level to the top of the frame, a standard 8-ton steel wheel roller will be used for the rolling and shall be included in the cost for frame adjustment. A 10-foot straight edge provided by the Contractor shall be used to ensure a level final placement. The concrete to be used shall be a **minimum** of MAG AA with High early Strength to attain a minimum of 2000 psi compressive strength in 24 hours. Mix design shall be submitted to the Contract Administrator for approval prior to the NTP date. The frame and finished surface shall not vary more than  $\pm \frac{1}{4}$ -inch from the 10-foot straightedge laid across the center axis of the frame and finished surface.

**For streets where the extended barricade hours are not used, no concrete shall be poured between 1:00 p.m. to 7:00 p.m., but shall occur the next morning during weekdays.**

**A #4 rebar hoop is required to be centered inside the concrete collar on all adjusted manhole frames and covers, also on all adjusted existing frames and covers for valves, survey monuments and sewer cleanouts.**

**NOTE (1):** Arizona Public Service Company manholes must be grouted on the inside and the outside for a waterproof seal.

**NOTE (2):** A company representative must be present at all times when adjusting Arizona Public Service Company manholes.

The Contractor will coordinate with the Contract Administrator and with representatives of the various utilities regarding the adjustment and inspection of their manholes. Utility companies' specifications shall be adhered to during adjustment. The Contractor shall be responsible for obtaining any additional specification requirements from the utility companies.

Payments for this type of work will be made at the unit prices bid per each regardless of the **type** of manhole or valve, in the applicable proposal pay item, which price shall be full compensation for all material and labor required to complete the work as described and specified herein.

The individual utility companies have the right to accept or reject the Contractor's bid for their portion of the frame and cover adjustment. If the Contractor's bid for frame and cover adjustment is rejected, the utility company will perform their own adjustment and the bid item quantity will be adjusted accordingly. Any utility inspection costs associated with the utility work will be the responsibility of the Contractor.

Southwest Gas may utilize the Contractor to adjust their manholes and valves. The Contractor shall adjust to Southwest Gas standards and requirements. The Contractor shall provide an approved schedule to Southwest Gas and notify them one (1) week prior to any work required. See Southwest Gas for contact persons.

Arizona Public Service Company may utilize the Contractor to adjust manholes. The Contractor shall adjust to APS standards. The Contractor shall provide an approved schedule to their Utility Representative one (1) week prior to any work required.

CenturyLink may utilize the Contractor to adjust their manholes. The Contractor shall adjust to CenturyLink standards. The Contractor shall provide an approved schedule to their Utility Representative one (1) week prior to any work required.

The Contractor shall maintain accurate records of utility adjustments so the Town can recover the adjustment costs from the appropriate utility.

The frames and covers shall be adjusted according to MAG Standard Details and the special provisions herein, except that the concrete collar shall extend up to finished grade.

**Manhole adjustment rings:**

At the Contractor's option, adjusting rings may be installed per MAG section 345.4. Where rings are installed but cannot be used and must be removed, no payment will be made. Adjusting rings shall be used only for manholes that are located at least 6 feet away from the lip of the concrete curb and gutter.

Each location must have sufficient depth of asphalt overlay to insure proper installation and operation of the ring.

**B. ADJUST EXISTING UNEXPOSED WATER/GAS VALVE FRAMES AND COVERS**

The Contractor will raise and adjust existing unexposed water/gas valve frames and covers. Unexposed covers will be identified by an eight (8)-inch solid painted circle. Paint color will be "Water Department Blue" for water valves and an approved color for gas valves.

In an attempt to locate a valve box, the Contractor will remove the existing asphalt surface a minimum distance of eighteen (18)-inches from the valve lid marking and to a depth of the total pavement surface prior to paving.

Replacements for uncovered frames or lids that are found missing, defective or damaged will be supplied by the contractor in coordination with local utility companies. Cost shall be incidental to the project and the responsibility of the Contractor.

If, after an adequate attempt, no valve box is found, the local utility company is to be notified.

**C. MAG STANDARD DETAIL 392 & CITY OF PHOENIX STANDARD DETAIL P1391: "DEBRIS CAP INSTALLATION"**

The Contractor is not required to install Debris cap for water valve adjustment in this project.

**D. VALVE LID REPLACEMENT**

The cost for picking up new valve lids, installing them, and dropping off the old lids to salvage as specified herein shall be incidental to unit price bid for "Adjust Existing Frame and Clean Cover for Valves" or unit price for "Adjust Existing Unexposed Water Valve" as appropriate. No additional payment will be made for this work.

**E. QUARTER SECTION MAPS: WATER AND SEWER LINES AND UTILITIES**

Available quarter section maps for water and sewer lines and other utilities shall be provided by the Town or the respective utility company.

**G. PRESSURE MANHOLE FRAMES AND COVERS**

The Contractor will rebuild and adjust pressure manhole frames and clean covers encountered on this project. The frames and covers shall be adjusted according to Standard Detail 523 and these special provisions, except that the concrete collar shall

extend up to finished grade. Scottsdale Manholes shall comply with Scottsdale Standard Detail #2270 attached as Exhibit "C".

#### **H. CLEAN OUT WATER VALVE BOX**

All water valve boxes shall be cleaned out to the bottom of the box and checked that an operating nut is in place on the valve. Contractor is not to operate the valve, only check that the nut is in place and report any deficiencies to the Contract Administrator. The Contract Administrator will notify the Water Company immediately if the nut is missing on any valve. **Any costs associated with this work shall be considered incidental to the contract and the responsibility of the Contractor.**

#### **I. MEASUREMENT**

The quantities in the bid tab are an estimate. Actual quantities will be measured in the field for adjustment. The quantities measured will be the actual number of frames, covers and valve boxes, adjusted and accepted. The Contractor shall maintain accurate records of utility adjustments so the Town can recover the adjustment costs from the appropriate utility.

#### **J. PAYMENT**

The quantities, as determined above, will be paid for at the contract price per unit of measurement respectively, for each of the particular items listed in the proposal. The payment shall be compensation in full for all materials, labor, equipment and incidentals necessary to complete the work.

## **ASPHALT CONCRETE:**

### **1.0 GENERAL:**

Mix design shall be PG76-22 PMTR as specified by EVAC detailed in Appendix D.

- A. The Job Mix Formula shall be provided by the Contractor and reviewed and approved by the Engineer.

### **8 REFUSE COLLECTION ACCESS**

At any time project construction requires the closure or disruption of traffic in any roadway, alley, or refuse collection easement such that normal refuse collection will be interrupted, the Contractor shall, prior to causing such closure or disruption, make arrangements with the local collection agencies and property owners in order that refuse collection service can be maintained. The Contract Administrator shall be notified of the arrangements made.

The contact information for local trash collection agencies is as follows:

|                    |              |  |
|--------------------|--------------|--|
| Area Disposal:     | 480-515-4300 | <a href="http://www.aredisposal.com">www.aredisposal.com</a> |
| Waste Management:  | 602-268-2222 | <a href="http://www.wm.com">www.wm.com</a>                   |
| Republic Services: | 602-225-0020 |  |

### **9 COOPERATION BETWEEN CONTRACTORS AND UTILITY COMPANIES.**

It shall be the responsibility of the Contractor to coordinate the work to ensure a smooth and orderly sequence of construction.

### **10 SUMMARY OF QUANTITIES**

The measurements indicated on the summary of quantities sheet are estimated and are for the Contractor's convenience only. Actual field measurements shall be verified by the Contractor. Any costs associated with field measurements shall be considered incidental to the contract.

### **11 ROYALTIES**

The Town of Carefree will not pay royalties which relate to the manufacture and application of asphalt-rubber products.

### **12 POWER BROOM**

The equipment used by the Contractor shall include a power pick-up broom, for both the paving and milling operation, on the job site at all times during the overlay operation to assure clean joints and to maintain a clean street prior to overlay or other work. If the Contract Administrator deems necessary, to maintain clean and safe streets during and after paving, up to two additional power pick-up brooms may be required. Any costs associated with this work shall be considered included in the cost of the overlay.

### **13 DUST PREVENTION**

The Contractor shall take whatever steps, procedures, or means to prevent dust conditions due to his construction operations in connection with this contract. The dust control measures shall be maintained at all times during construction of the project, to the satisfaction of the

Contract Administrator, in accordance with the requirements of the "Maricopa County Health Department Air Pollution Control Regulations".

Prior to the pre-construction conference, the Contractor shall have an approved dust control plan and permit, approved by the Maricopa County Division of Air Pollution Control. For information and requirements for dust control plan submittal, please contact the following:

Maricopa County Division of Air Pollution Control  
2406 S. 24<sup>th</sup> Street, Suite E-214  
Phoenix, Arizona 85034  
(602)-506-6727

All cost associated with the submittal, approval, and implementation of the dust control plan, as approved by the County, shall be considered incidental to the project and the responsibility of the Contractor.

#### **14 DAILY SCHEDULE**

The Contractor shall provide a schedule every Thursday for the following week's work when requested by the Contract Administrator. The schedule shall include, but is not limited to the following: A map indicating the streets to be resurfaced each day including limits, the sequence of streets for each day's work, and which side of the street is to be resurfaced for each day's work.

**A weekly construction meeting will be conducted by the Contract Administrator at a set time.**

#### **15 BID QUANTITIES**

The quantities listed in the specifications are for bid purposes. The actual quantities provided to the Contractor may be adjusted to accommodate field requirements.

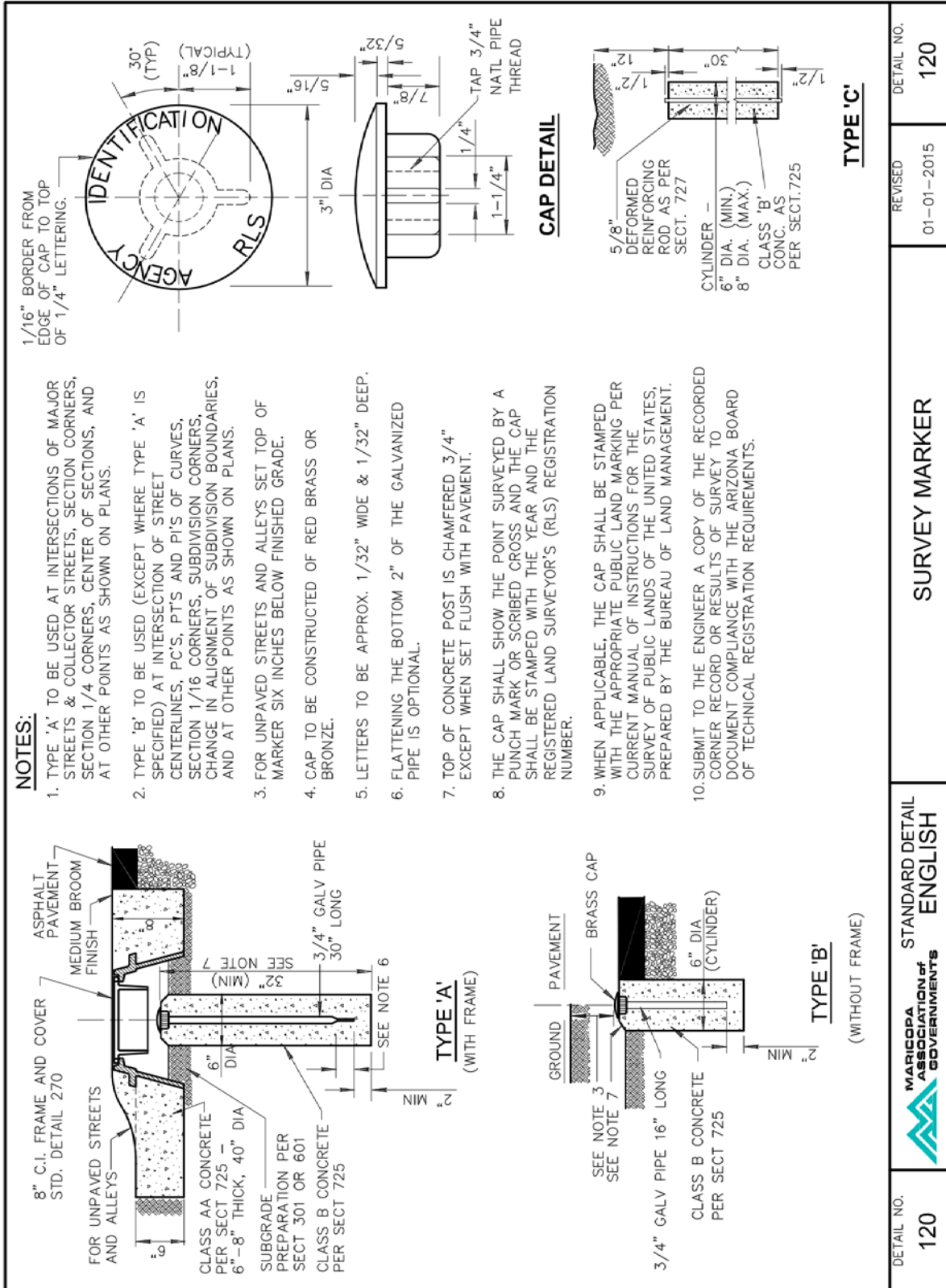

Town of Carefree Note: A surveyor registered in the state of Arizona shall reference the location of the survey marker.



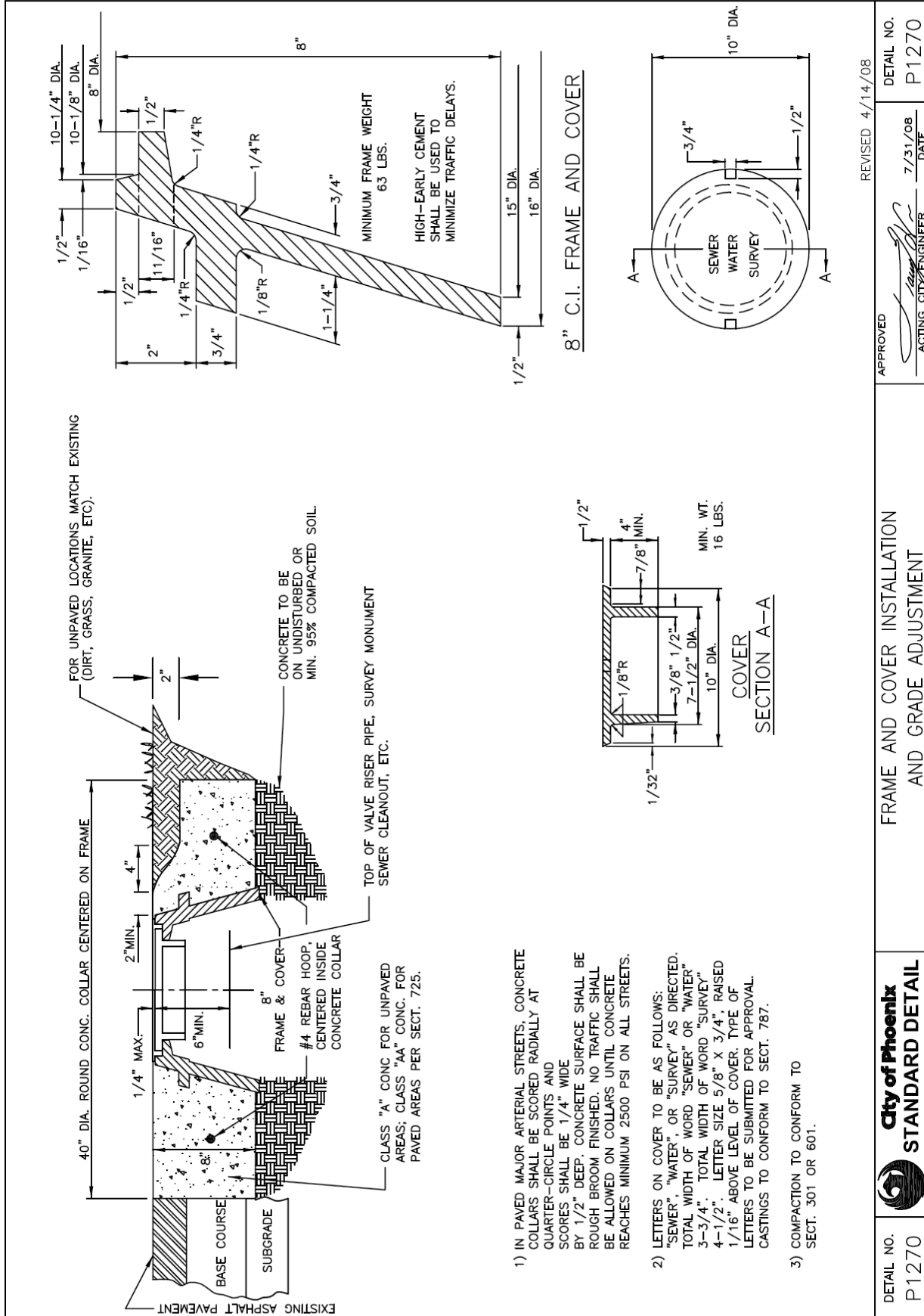

**NOTES:**

1. VALVE OPERATION NUT EXTENSION: SEE DETAIL P1391-1 EXTENSION TO VALVE STEMS REQUIRED ON ALL VALVES WHERE OPERATING NUT IS OVER 5' BELOW SURFACE. LENGTH TO FIT EACH INSTALLATION.
2. IF TWO OR MORE JOINTS OF C900 PVC "WATER" PIPE RISER ARE NEEDED, THEY SHALL BE COUPLED AND GLUED WITH APPROPRIATE PVC GLUE TO FORM A DEBRIS-TIGHT JOINT.
3. VALVE BOX SHALL BE ADJUSTED TO THE FINISH GRADE AFTER PLACING THE ASPHALTIC CONCRETE SURFACE.
4. USE PARKSON TYLER, APCO, OR EQUAL DEEP SKIRTED COVER LID (4" DEEP OR MORE) C.I. MIN. T.S. 30,000 P.S.I. USE SECURE POLYMER VALVE BOX LID WITH LID-RETENTION ELASTOMERIC SEAL PER DETAIL P1270-1 WHERE "SECURE" LIDS ARE SPECIFIED.
5. GROUND BELOW CONCRETE PAD TO BE COMPACTED TO MIN. 95% OF MAX DENSITY.
6. INSTALL DEBRIS CAP PER DETAIL P1165.

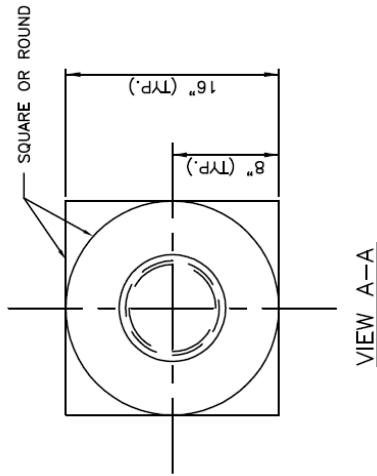
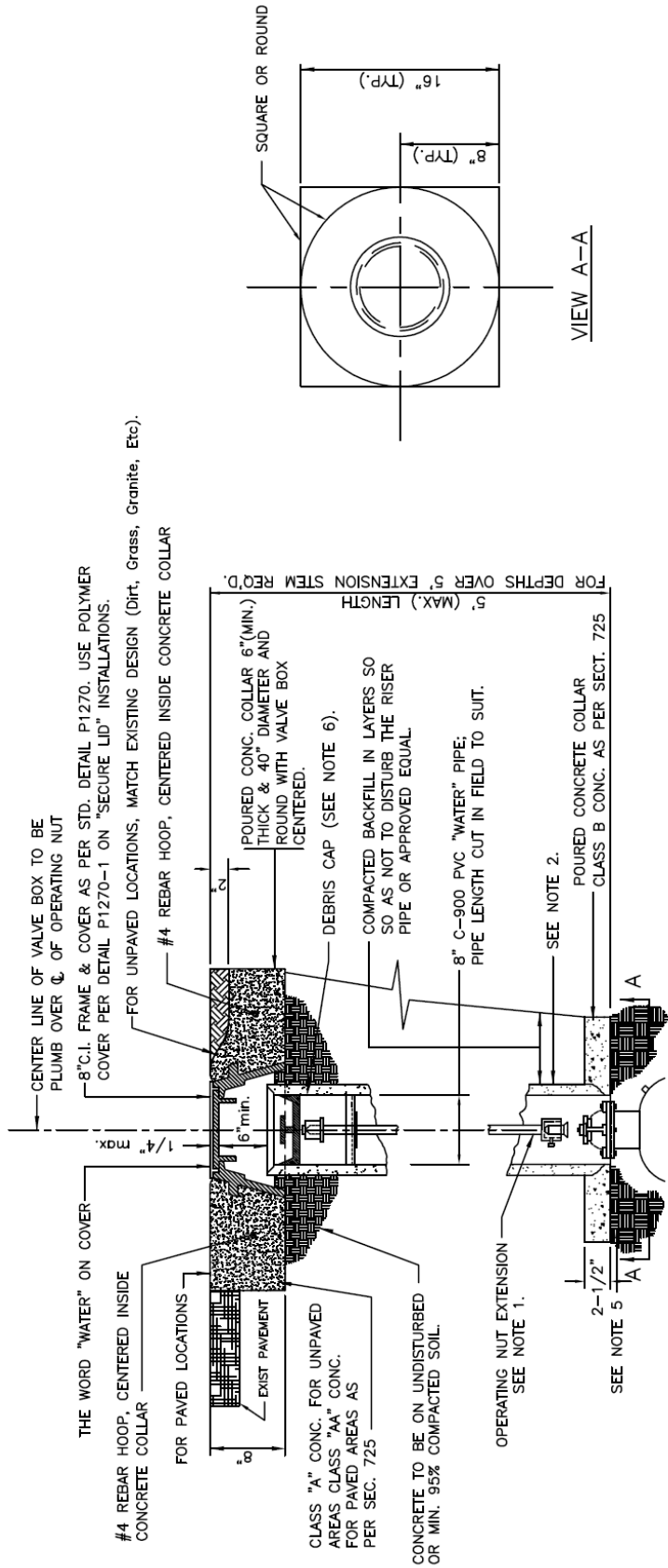

|                            |  |                        |   |   |
|----------------------------|--|------------------------|---|---|
| DETAIL NO.<br><b>P1391</b> | <b>City of Phoenix</b><br><b>STANDARD DETAIL</b> | VALVE BOX INSTALLATION | APPROVED<br><br>ACTING CITY ENGINEER | REVISION 4/14/08<br>DATE<br>7/31/08<br>DETAIL NO.<br><b>P1391</b> |
|----------------------------|--|------------------------|---|---|

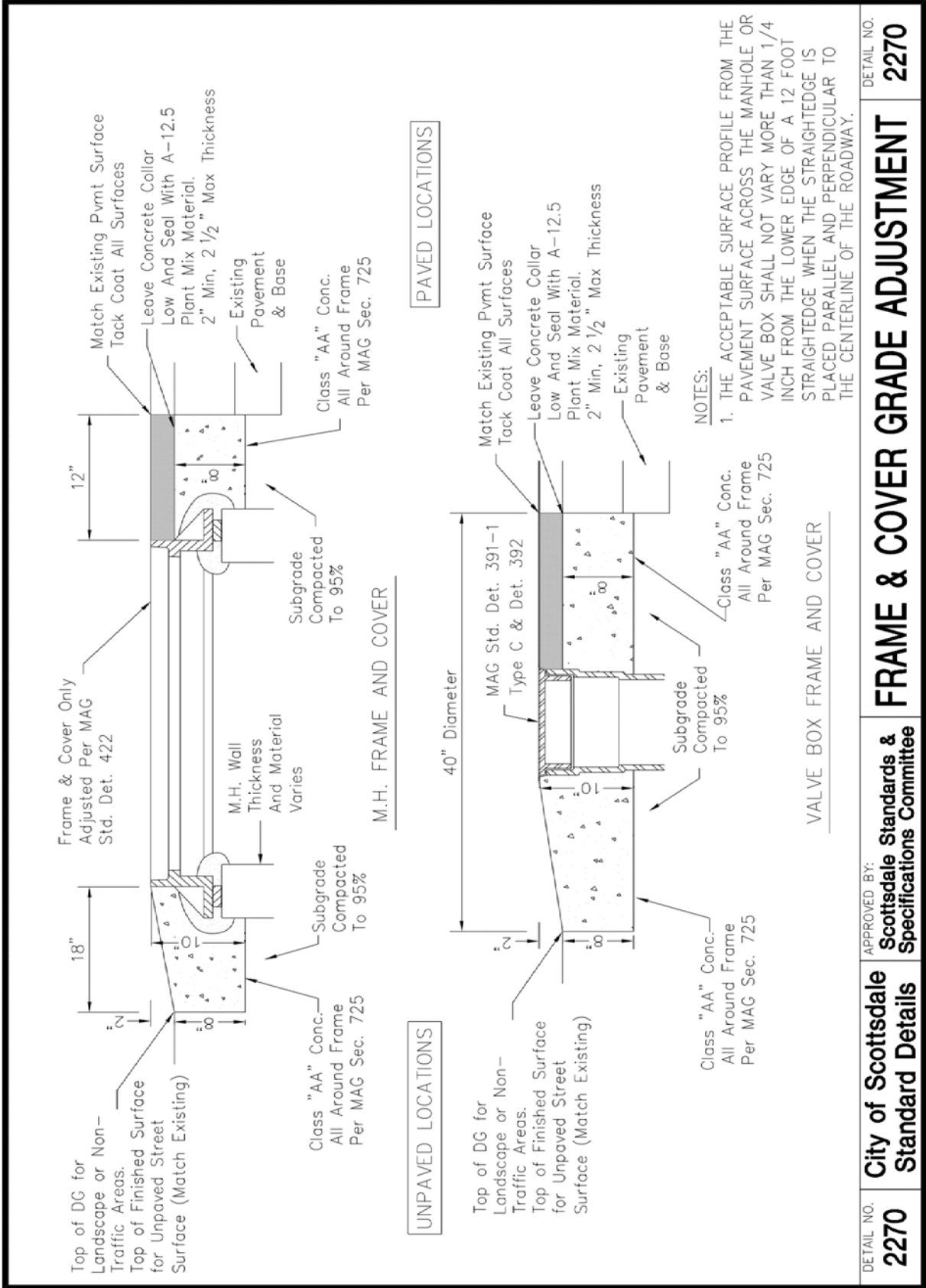

|  |  |   |
|--|--|---|
| DETAIL NO.<br><b>2270</b>                  | APPROVED BY:<br><b>Scottsdale Standards &amp; Specifications Committee</b> | DETAIL NO.<br><b>2270</b>                 |
| <b>City of Scottsdale Standard Details</b> |  | <b>FRAME &amp; COVER GRADE ADJUSTMENT</b> |

**CONTRACT FORMS**

**NOTICE OF AWARD**

**PROJECT NUMBER:** 2024-100

**PROJECT NAME:** PAVEMENT MAINTENANCE PROJECTS 2023-2024

TO \_\_\_\_\_  
\_\_\_\_\_  
\_\_\_\_\_

The Town of Carefree has considered the Bid submitted by you for the above-described Work in response to the Advertisement for Bids dated \_\_\_\_\_, 2023.

You are hereby notified that you were awarded the Contract by the Carefree Town Council on \_\_\_\_\_, 2023 in the amount of \$\_\_\_\_\_.

You are required by the Terms and Conditions of this bid to execute the Construction Contract and to furnish Contractor's Performance and Payment Bonds and submit the appropriate Certificate(s) of Insurance within seven (7) days from the date of this Notice.

If you fail to execute the Construction Contract, furnish the required bonds, and submit Insurance Certificate(s) within seven (7) days from the date of this Notice, the Town will consider this as a forfeiture of your Bid Bond. The Town will be entitled to such other rights as may be granted by law.

You are required to return an acknowledged copy of this NOTICE OF AWARD to the Town of Carefree.

Dated this \_\_\_\_\_ day of \_\_\_\_\_, 2023.

**TOWN OF CAREFREE**

By: \_\_\_\_\_

Title: \_\_\_\_\_

**ACCEPTANCE OF NOTICE:**

**PROJECT NUMBER:** 2024-100

**PROJECT NAME:** PAVEMENT MAINTENANCE PROJECTS 2023-2024

Receipt of the above NOTICE OF AWARD is hereby acknowledged.

BY: \_\_\_\_\_

Title: \_\_\_\_\_

Subscribed and sworn to before me this \_\_\_\_\_ day of \_\_\_\_\_ 2023.

\_\_\_\_\_  
NOTARY PUBLIC

My Commission Expires:

**TOWN OF CAREFREE  
CONTRACTOR AGREEMENT**

**PROJECT NUMBER:** 2024-100

**PROJECT NAME:** PAVEMENT MAINTENANCE PROJECTS 2023-2024

THIS CONTRACTOR AGREEMENT (hereinafter "the Agreement"), is made and entered into effective this \_\_\_\_\_ day of \_\_\_\_\_, 2023, between \_\_\_\_\_, (hereinafter "CONTRACTOR") and the Town of Carefree, Arizona (hereinafter "TOWN"), an Arizona municipal corporation. (CONTRACTOR and TOWN hereinafter designated "the PARTIES").

1. **Project:** Installation of PAVEMENT MAINTENANCE PROJECTS 2023-2024 in Carefree, Arizona, being project number 2024-100 (hereinafter "the Project").
2. **Scope of Services:** TOWN requests CONTRACTOR to perform Project services ("the Work") described on the bid schedule and as follows:

**Overview:**

1. Cape Seal (Slurry Seal over Chip Seal)
2. Adjust water valves, other utility structures and monuments
3. Crack seal
4. Striping

Work shall be performed in accordance with the contract documents, which consist of the plans and specifications therein, MAG Uniform Standard Specifications for Public Works Construction (2012 Edition) where applicable, Supplemental Conditions, if any, General Conditions, the Town of Carefree Town Code, industry accepted quality workmanship, and other specifications and details contained within the contract documents and the Contractor's bid, as accepted (to the extent not inconsistent with the foregoing.) Performance Bond, Payment Bond, Certificates of Insurance and Change Orders, if any, are by this reference made a part of the Agreement to the same extent as if set forth herein in full.

Contractor agrees to perform the Work in consideration for and subject to the terms and conditions hereinafter set forth, and in accordance with all federal, state, county and Town laws, statutes, ordinances, rules and regulations applicable to the Project and the Work. Contractor represents and warrants that its work, findings, designs, plans and specifications, recommendations and professional advice are or will be done, made or prepared in a good and workmanlike manner and in accordance with generally accepted contracting practices. Contractor further covenants and agrees, at its own cost and expense, to do the Work and install the required material as called for by the Agreement, free and clear of all claims, liens and charges whatsoever in the manner and under the conditions specified within the time, or times, stated in the bid form.

3. **Payment:** TOWN shall pay CONTRACTOR as compensation for the Work the sum of \$\_\_\_\_\_.

4. **Method of Payment:** Each month, CONTRACTOR shall furnish to TOWN a statement of the Work performed for compensation during the preceding month, as authorized by the Agreement. TOWN shall pay statement within 30 days of receipt. Final payment shall be made within forty (40) days after final inspection and acceptance of the Work.

CONTRACTOR shall be solely responsible for all costs incurred in connection with the accomplishment of the Work for the Project. In addition to any other right and remedy it may have, TOWN may deduct from any amount due or to become due to CONTRACTOR, any amount necessary to protect TOWN, in TOWN's reasonable opinion, from any loss arising from CONTRACTOR's breach of the Agreement.

5. **Additional Services:** It is agreed that any changes in the scope of the Work requested by TOWN or TOWN's representatives or by reason of revisions or changes in any applicable law, regulation, policy standard or personnel of any governmental agency, district or utility company having jurisdiction over all or any part of the Work or Project after the date of the Agreement, shall constitute extra work, and CONTRACTOR shall be compensated for said extra work as agreed between CONTRACTOR and TOWN or on a time-and-expense basis, subject to and conditioned upon a written change order signed by TOWN for any such extra work. CONTRACTOR agrees that it will make no claim for additional fees or expenses other than those specifically set forth in the Agreement and in written change orders signed by TOWN. In the absence of a written change order signed by TOWN, CONTRACTOR agrees that it will have no claim for compensation for extra work and hereby releases TOWN from any such claim.
6. **Intent of Independent Contractor Relationship:** The PARTIES intend that the relationship created by the Agreement shall be that of service recipient and independent contractor and not that of employer and employee. In this regard, CONTRACTOR shall retain the exclusive right to control and direct all details of the Work.

For all purposes, including but not limited to the Federal Insurance Contributions Act ("FICA"), the Social Security Act, the Federal Unemployment Tax Act ("FUTA"), income tax withholding requirements, and all other federal, state and local laws, rules and regulations, CONTRACTOR (and CONTRACTOR's respective employees, if any) shall be treated as an independent contractor and not as an employee with respect to the TOWN.



- 7. No Benefits:** None of the benefits, if any, which are provided by TOWN to its employees, shall be available to CONTRACTOR (or CONTRACTOR's employees, if any, which for purposes of this Paragraph 7 shall be included in the term "CONTRACTOR"). CONTRACTOR's exclusion from benefit programs maintained by TOWN is a material term of the terms of compensation negotiated by the PARTIES and is not premised on CONTRACTOR's status as a non-employee with respect to TOWN. To the extent that CONTRACTOR may become eligible for any benefit programs maintained by TOWN (regardless of the timing of or reason for eligibility), CONTRACTOR hereby waives CONTRACTOR's right to participate in these programs. CONTRACTOR's waiver is not conditioned on any representation or assumption concerning CONTRACTOR's status under the common law test. CONTRACTOR agrees that consistent with CONTRACTOR's independent contractor status, CONTRACTOR will not apply for any government-sponsored benefits that are intended to apply to employees.
- 8. Workers' Compensation Coverage:** CONTRACTOR acknowledges that as an independent contractor, CONTRACTOR and CONTRACTOR'S employees, if any, shall not be entitled to workers' compensation benefits from TOWN.
- 9. Equipment and Tools:** CONTRACTOR shall provide and be responsible for maintaining any equipment and tools that CONTRACTOR uses, or determines is necessary, to accomplish the Work.
- 10. Manner, Time and Location:** The PARTIES agree that time is of the essence as it relates to completion of the Work under the Agreement. CONTRACTOR shall have the right to perform the Work in such manner, at such times, and at such locations as CONTRACTOR deems appropriate. TOWN shall have no right to interfere with CONTRACTOR's judgment with respect to manner, time, and place of performance of the Work, so long as any performance deadlines that may be established by TOWN are satisfied. CONTRACTOR agrees that any damages incurred under this provision of the Agreement shall be defined pursuant to §108.9, Failure to Complete on Time of the MAG General Conditions.
- 11. Right to Engage Assistants:** CONTRACTOR shall have the right to engage others to assist in the accomplishment of the Work. CONTRACTOR shall be solely responsible for paying all compensation owed to any assistants CONTRACTOR engages and for paying, and/or withholding and remitting to the appropriate government agency, any applicable employment taxes that might be owed with respect to this compensation. CONTRACTOR also shall indemnify and hold TOWN harmless for, from and against any and all liabilities attributable to the obligations imposed on CONTRACTOR under the Agreement. The PARTIES acknowledge that CONTRACTOR shall retain the exclusive right to determine which workers CONTRACTOR shall engage for these purposes.
- 12. Performing Services for Others:** TOWN agrees that CONTRACTOR may perform services for others, so long as the performance of these services does not interfere with the completion of the Work.

- 13. Warranties:** CONTRACTOR warrants all services and materials CONTRACTOR provides as part of the Work against defects to the services and materials so provided for in the workmanship according to MAG §108.8.
- 14. Default:** CONTRACTOR understands and agrees that stopping work including withholding delivery of documents, applications or other work product to TOWN, any agency or other person, other than for nonpayment of amounts due under the Agreement, shall constitute a default under the Agreement and shall result in liability on the part of CONTRACTOR for damages including liability by reason of work stoppage. Upon any default under the Agreement by CONTRACTOR, including but not limited to any stoppage other than for non-payment of amounts due under the Agreement, TOWN shall have no further obligation to pay any amounts due under the Agreement to CONTRACTOR.
- 15. Documents:** TOWN shall receive and may retain any and all work product of CONTRACTOR, including all documents, plans, drawings, specifications, analyses, designs, models, ideas, reports, charts and computer programs prepared by or on behalf of CONTRACTOR or otherwise utilized by CONTRACTOR (collectively "Work Product") in the discharge of its responsibilities under the Agreement, which Work Product shall immediately thereafter become the sole and exclusive property of TOWN.

TOWN is also granted a royalty-free, perpetual license to use, reproduce, copy and distribute the Work Product for itself and for its other contractors, subcontractors and consultants either as needed in connection with the Project contemplated under the Agreement or as needed for reference and information related to the use, occupancy or maintenance of the completed Project.

- 16. Termination:** TOWN may terminate the Agreement with or without cause by giving thirty (30) days' written notice to CONTRACTOR. In such event, TOWN shall forthwith pay CONTRACTOR in full for all work previously authorized in writing and satisfactorily performed prior to the effective date of termination.
- 17. Indemnification:** CONTRACTOR agrees to indemnify and save harmless TOWN and its elected and appointed officers, agents, boards, commissions, employees, attorneys and representatives from all suits, including attorneys' fees and costs of litigation, actions, laws damage, expense, cost or claims, of any character or of any nature arising out of or in connection with any act or omission of CONTRACTOR, its agents and employees, and of any subcontractor, its agents and employees, in the course of the performance of the Work or in connection with the Project or the Agreement which results directly or indirectly in the injury to or death of any person or persons, or the damage of any property of any person or persons, or on account of act, claim or amount arising or recovered under workers' compensation law, or arising out of any failure of CONTRACTOR or those acting under CONTRACTOR to conform to any statutes, ordinances, regulations, laws or court decrees, or which results in a claim, lien or charge (in which event CONTRACTOR shall pay and take all steps necessary to remove the claim, lien or charge at no cost to TOWN). It is the

intent of the PARTIES that TOWN shall, in all instances, be indemnified and held harmless by CONTRACTOR against any liability, losses and damages of any nature whatsoever for or on account of any injuries to or death of persons or damages to or destruction of property belonging to any person arising out of or in any way connected with the Agreement or the performance of the Work, whether the liability, losses and damages are caused by or alleged to be caused in whole or in part by the negligence, gross negligence or fault of TOWN or any of its officers, agents, attorneys or employees.

Prior to commencing any work under the Agreement, CONTRACTOR will procure and maintain a certificate of insurance covering liability and property damage issued by an insurance company authorized to transact business in the State of Arizona, as shall protect CONTRACTOR and its employees, agents and any other person or entity responsible for performing the Work under the Agreement, from claims for damages for personal injury, including death, as well as from claims for property damage which may arise from or be related to the Work, the Project or the Agreement. The certificate of insurance shall name TOWN as an additional insured and shall be delivered to TOWN prior to commencing any work under the Agreement. Such insurance shall be primary and shall provide coverage for all liability under the Agreement. The policy limits of such liability and property damage insurance shall contain not less than the following limits of coverage: (1) \$1 million for death or bodily injury or loss sustained by any one person per occurrence; (2) \$2 million for death or bodily injury or loss sustained by more than one person per occurrence; and (3) \$1 million for loss sustained for damage to property occasioned per occurrence. Such insurance shall be maintained in full force and effect until all work under the Agreement is complete.

- 18. Notices:** Any notice under the Agreement must be in writing and shall be effective upon delivery by hand or three (3) business days after deposit in the United States mail, postage prepaid, certified or registered, and addressed to TOWN or to CONTRACTOR at the corresponding address below. CONTRACTOR shall be obligated to notify TOWN in writing of any change in his address. Notices of change of address shall be effective only when done in accordance with this paragraph.

**To TOWN:** Gary S. Neiss  
Town Administrator  
Town of Carefree  
8 Sundial Circle  
P. O. Box 740  
Carefree, Arizona 85377

**With a copy to:** Michael Wright  
Town Attorney  
Sherman & Howard LLC  
7047 E. Greenway Parkway, Suite 155  
Scottsdale, AZ 85254-8113

**To CONTRACTOR:** \_\_\_\_\_  
\_\_\_\_\_  
\_\_\_\_\_

- 19. **Integration:** The Agreement is intended to be the final, complete, and exclusive statement of the terms of CONTRACTOR'S engagement by TOWN. The Agreement supersedes all other prior and contemporaneous agreements and statements, whether written or oral, express or implied, pertaining in any manner to the engagement of CONTRACTOR, and it may not be contradicted by evidence of any prior or contemporaneous statements or agreements. To the extent that the practices, policies, or procedures of TOWN, now or in the future, apply to CONTRACTOR and are inconsistent with the terms of the Agreement, the provisions of the Agreement shall control.
- 20. **Amendments; Waivers:** The Agreement may not be amended except by an instrument in writing, signed by each of the PARTIES. Failure to exercise any right under the Agreement shall not constitute a waiver of such right.
- 21. **Assignment; Successors and Assigns:** Neither TOWN nor CONTRACTOR shall assign any rights or obligations under the Agreement. The Agreement shall be binding upon the PARTIES, their heirs, successors, transferees and assigns.
- 22. **Attorneys' Fees:** In any legal action, arbitration, or other proceeding brought to enforce or interpret the terms of the Agreement, the prevailing PARTY shall be entitled to recover reasonable attorneys' fees and costs.
- 23. **Governing Law:** The Agreement shall be governed by and construed in accordance with the law of the State of Arizona.
- 24. **Interpretation:** The Agreement shall be construed as a whole, according to its fair meaning, and not in favor of or against any party. By way of example, and not in limitation, the Agreement shall not be construed in favor of the party receiving a benefit or against the party responsible for any particular language in the Agreement. Captions are used for reference purposes only and should be ignored in the interpretation of the Agreement.

- 25. **Severability:** If any one or more of the provisions of the Agreement shall be held or found to be invalid, illegal or unenforceable in any respect, the validity, legality and enforceability of the remaining provisions shall not in any way be affected or impaired thereby.
- 26. **Contractor Acknowledgment:** CONTRACTOR acknowledges that CONTRACTOR has had the opportunity to consult legal counsel in regard to the Agreement, that CONTRACTOR has read and understands the Agreement, that CONTRACTOR is fully aware of its legal effect, and that CONTRACTOR has entered into it freely and voluntarily and based on Contractor's own judgment and not on any representations or promises other than those contained in the Agreement.
- 27. **Certification:** I, \_\_\_\_\_, the \_\_\_\_\_ of CONTRACTOR, hereby certify that I have read and understood and agree to the above provisions of the Agreement and have had an opportunity to seek advice regarding the provisions that I found to be ambiguous.

The PARTIES have duly executed the Agreement as of the date first written above.

**“The TOWN”**

TOWN OF CAREFREE, ARIZONA,  
an Arizona municipal corporation

By \_\_\_\_\_

Its \_\_\_\_\_

**“CONTRACTOR”**

\_\_\_\_\_

By \_\_\_\_\_

Its \_\_\_\_\_

Social Security Number or  
Employer Identification Number:

\_\_\_\_\_

IN WITNESS WHEREOF, three (3) identical counterparts of this contract, each of which shall for all purposes be deemed an original thereof, have been duly executed by the PARTIES herein above named, on the date and year first above written.

**CONTRACTOR:**

**TOWN OF CAREFREE**

\_\_\_\_\_  
Company Name

By: \_\_\_\_\_  
John Crane, Mayor

BY: \_\_\_\_\_  
Signature

**ATTEST:**

\_\_\_\_\_  
Individual Name/Title

By: \_\_\_\_\_  
Kandace French, Town Clerk

ADDRESS: \_\_\_\_\_  
\_\_\_\_\_

**CORPORATE SEAL:**

**APPROVED AS TO FORM:**

\_\_\_\_\_  
Michael Wright, Town Attorney

**CONTRACT BOND**

**STATUTORY PERFORMANCE BOND  
PURSUANT TO  
TITLE 34, CHAPTER 2, ARTICLE 2,  
OF THE  
ARIZONA REVISED STATUTES**

(Penalty of this bond must be 100% of the Contract Amount)

**KNOW ALL MEN BY THESE PRESENTS:**

That, \_\_\_\_\_ (hereinafter called the Principal) as Principal, and \_\_\_\_\_, a corporation organized and existing under the laws of the State of \_\_\_\_\_ with its principal office in the City of \_\_\_\_\_, (hereinafter called the Surety), as Surety, are held and firmly bound unto the Town of Carefree, County of Maricopa, State of Arizona in the amount of \_\_\_\_\_ Dollars (\$ \_\_\_\_\_), for the payment whereof, the said Principal and Surety bind themselves, and their heirs, administrators, executors successors and assigns, jointly and severally, firmly by these presents.

**WHEREAS**, the Principal has entered into a certain written contract with the Town of Carefree, dated the \_\_\_\_\_ day of \_\_\_\_\_, 2023 for Project Number 2024-100, which contract is hereby referred to and made a part hereof as fully and to the same extent as if copied at length herein.

**NOW THEREFORE**, the condition of this obligation is such, that if the Principal faithfully performs and fulfills all of the undertakings, covenants, terms, conditions and agreements of the contract during the original term of the contract and any extension of the contract, with or without notice to the surety, and during the life of any guaranty required under the contract, and also performs and fulfills all of the undertakings, covenants, terms, conditions and agreements of all duly authorized modifications of the contract that may hereafter be made, notice of which modifications to the surety being hereby waived, the above obligation is void. Otherwise, it remains in full force and effect.

PROVIDED HOWEVER, that this Bond is executed pursuant to the provisions of A.R.S.34-222 and A.R.S.34-223 and all liabilities on this Bond shall be determined in accordance with these sections to the extent as if they were copied at length in this agreement. If the provisions of this bond conflict with the terms of these sections, the latter control.

The prevailing party in a suit on this bond shall be entitled to such reasonable attorney's fees as may be fixed by a Judge of the Court.

WITNESS our hands the \_\_\_\_\_ day of \_\_\_\_\_, 2023.

\_\_\_\_\_  
PRINCIPAL

\_\_\_\_\_  
BY:

\_\_\_\_\_  
SURETY (SEAL)

\_\_\_\_\_  
AGENCY OF RECORD

AGENCY ADDRESS

\_\_\_\_\_  
\_\_\_\_\_



**LABOR AND MATERIALS BOND  
STATUTORY PAYMENT BOND  
PURSUANT TO  
TITLE 34, CHAPTER 2, ARTICLE 2,  
OF THE  
ARIZONA REVISED STATUTES**

(Penalty of this bond must be 100% of the Contract Amount)

**KNOW ALL MEN BY THESE PRESENTS:**

That, \_\_\_\_\_ (hereinafter called the Principal), as Principal, and \_\_\_\_\_ a corporation organized and existing under the laws of the State of \_\_\_\_\_, with its principal office in the City of \_\_\_\_\_ (hereinafter called the Surety), as Surety, are held and firmly bound unto the Town of Carefree, County of Maricopa, State of Arizona (hereinafter called the Obligee), in the amount of \_\_\_\_\_ Dollars (\$\_\_\_\_\_), for the payment whereof, the said Principal and Surety bind themselves, and their heirs, administrators, executors, successors and assigns, jointly and severally, firmly by these presents.

**WHEREAS**, the Principal has entered into a certain written contract with the Town of Carefree dated the \_\_\_\_\_ day of \_\_\_\_\_, 2023 for Project No. 2024-100, which contract is hereby referred to and made a part hereof as fully and to the same extent as if copied at length herein.

**NOW, THEREFORE**, the condition of this obligation is such, that if the said Principal shall promptly pay all monies due to all persons supplying labor or materials to the Principal or the Principal's subcontractors in the prosecution of the work provided for in said contract, this obligation is void. Otherwise, it remains in full force and effect.

**PROVIDED, HOWEVER**, that this bond is executed pursuant to the provisions of Title 34, Chapter 2, Article 2, of the Arizona Revised Statutes, and all liabilities on this bond shall be determined in accordance with the provisions, conditions and limitations of Title 34,

Chapter 2, Article 2, Arizona Revised Statutes, to the same extent as if they were copied at length in herein.

The prevailing party in a suit on this bond shall be entitled to such reasonable attorney fees as may be fixed by a Judge of the Court.

WITNESS our hands the \_\_\_\_\_ day of \_\_\_\_\_, 2023.

\_\_\_\_\_  
PRINCIPAL

\_\_\_\_\_  
BY:

\_\_\_\_\_  
SURETY

(SEAL)

\_\_\_\_\_  
AGENCY OF RECORD

\_\_\_\_\_  
AGENCY ADDRESS:

\_\_\_\_\_  
\_\_\_\_\_  
\_\_\_\_\_

## TOWN OF CAREFREE CERTIFICATE OF INSURANCE

|                              |  |  |   |
|------------------------------|--|--|---|
| Town Dept: PUBLIC WORKS      | Project Title: CAVE CREEK ROAD IMPROVEMENTS AND<br>PEDESTRIAN CROSSWALK IMPROVEMENTS | PROJECT #2024-100                                |   |
| Companies Affording Coverage |  | Current State of Arizona<br>License              | Current A.M.<br>Best Rating                     |
| Producer:                    | A. _____<br>B. _____<br>C. _____<br>D. _____<br>E. _____                             | Yes<br>_____<br>_____<br>_____<br>_____<br>_____ | NO<br>_____<br>_____<br>_____<br>_____<br>_____ |
| Insured:                     |  |  |   |

This is to certify that the insurance policies listed below have been issued to the insured named above for the policy period indicated

| Co Ltr | TYPE OF INSURANCE   | POLICY NUMBER | POLICY EFFECTIVE DATE<br>(mm/dd/yy) | POLICY EFFECTIVE DATE<br>(mm/dd/yy) | LIMITS<br>(.000)  |
|--------|---|---------------|-------------------------------------|-------------------------------------|---|
|        | General Liability<br><input type="checkbox"/> Commercial General Liability<br><input type="checkbox"/> Occurrence <input type="checkbox"/> Claims Made<br><input type="checkbox"/> Owner's & Contractors Prot.<br><input type="checkbox"/> Per Project<br><input type="checkbox"/> Product/Completed Operations |               |                                     |                                     | General Aggregate \$ _____<br>Products-Comp/op Agg. \$ _____<br>Personal & Adv. Injury Each Occurrence \$ _____<br>Fire Damage (any one fire) \$ _____<br>Med. Exp. (any one person) \$ _____ |
|        | Automobile Liability<br><input type="checkbox"/> Any Auto<br><input type="checkbox"/> All Owned Autos<br><input type="checkbox"/> Scheduled Autos<br><input type="checkbox"/> Hired Autos<br><input type="checkbox"/> NonOwned Autos<br><input type="checkbox"/> Garage Liability                               |               |                                     |                                     | Combined Single Limit<br>Bodily Injury (per person) \$ _____<br>Bodily Injury (per accident) \$ _____<br>Property Damage \$ _____   |
|        | Professional Liability<br><input type="checkbox"/> Type _____<br><input type="checkbox"/> Claims Made <input type="checkbox"/> Occurrence   |               |                                     |                                     | Each Claim \$ _____<br>All Claims \$ _____  |
|        | Excess Liability<br><input type="checkbox"/> Umbrella Form<br><input type="checkbox"/> Other than umbrella form<br><input type="checkbox"/> Claims Made <input type="checkbox"/> Occurrence   |               |                                     |                                     | Each Occurrence \$ _____<br>Aggregate \$ _____  |
|        | Builders Risk   |               |                                     |                                     |   |
|        | Other   |               |                                     |                                     |   |

**Description of Operations/Locations/Vehicles/Special Items:**

Town of Carefree, its representatives, agents and employees, is an Additional Insured under Commercial General Liability ISO Form CG 20 10 11 85 or equivalent, Auto Liability ISO Form CA 20 48 or equivalent, and Excess Liability follow form to underlying coverage. All cited insurance shall be primary coverage and waive rights to recovery (subrogation), including Workers Compensation, against Town of Carefree. No policy shall be canceled or materially changed without 30 days advance written notice. Certificate not valid unless signed by authorized representative of Insurance Company.

|   |  |
|---|--|
| CERTIFICATE HOLDER/ADDITIONAL INSURED<br>Town of Carefree<br>8 Sundial Circle<br>PO Box 740<br>Carefree, AZ 85377 | Authorized Representative of the insurance company(ies)<br>Signature: _____<br>Date: _____ |
|---|--|

**NOTICE TO PROCEED**

PROJECT No: 2024-100

DESCRIPTION: PAVEMENT MAINTENANCE PROJECTS 2023-2024

In accordance with the Contract dated \_\_\_\_\_, you are hereby notified to commence work on \_\_\_\_\_ and you are to complete the WORK within ninety (90) consecutive calendar days thereafter. The date of completion of all WORK is therefore \_\_\_\_\_. Official time extensions thereto shall be considered and authorized in strict conformance with General Conditions or M.A.G. Standard Specifications.

TOWN OF CAREFREE

BY: \_\_\_\_\_

ACCEPTANCE OF NOTICE

Receipt of the above NOTICE TO PROCEED is hereby acknowledged.

BY: \_\_\_\_\_

TITLE: \_\_\_\_\_

Subscribed and sworn to before me this \_\_\_\_\_ day of \_\_\_\_\_, 2023.

\_\_\_\_\_  
NOTARY PUBLIC My Commission Expires

CONTRACTOR'S NOTICE OF FINAL PAY ESTIMATE

PROJECT #: 2024-100

DESCRIPTION: PAVEMENT MAINTENANCE PROJECTS 2023-2024

To the Town of Carefree, Arizona:

The final pay estimate of \_\_\_\_\_ Dollars (\$\_\_\_\_\_) which represents total and complete payment under the terms of the contract, fully and completely reflects the actual quantities of work performed. Said final quantities were mutually measured and agreed upon by authorized representatives of the undersigned and the Town of Carefree. Upon acceptance by the CONTRACTOR of the Final Payment under the Final Pay Estimate, the CONTRACTOR releases and waives all claims arising out of the Contract.

Signed and dated this \_\_\_\_\_ day of \_\_\_\_\_ 2023.

BY: \_\_\_\_\_

Title: \_\_\_\_\_

For: \_\_\_\_\_

STATE OF ARIZONA            )  
) ss  
COUNTY OF MARICOPA        )

The foregoing instrument was subscribed and sworn to before me this \_\_\_\_\_ day of \_\_\_\_\_, 2023.

\_\_\_\_\_  
Notary Public

My Commission expires:

**CONTRACTOR'S NOTICE OF FINAL ACCEPTANCE**

PROJECT #: 2024-100

DESCRIPTION: CAREFREE PAVEMENT MAINTENANCE PROJECTS 2023-2024

TO: \_\_\_\_\_

DATE: \_\_\_\_\_

\_\_\_\_\_

\_\_\_\_\_

Construction on the above project was completed on \_\_\_\_\_, 2023 and on \_\_\_\_\_, 2023 a final inspection was made of the subject improvements by this office. The work substantially conforms to the approved plans and specifications. We, therefore, accept the work.

Approved By:

\_\_\_\_\_

Contract Administrator

cc: Town Clerk

Accounting Director

Other:

**AFFIDAVIT REGARDING SETTLEMENT OF CLAIMS**

PROJECT # : **2024-100**

DESCRIPTION : **CAREFREE PAVEMENT MAINTENANCE PROJECTS 2023-2024**

To the Town of Carefree, Arizona

Gentlemen:

This is to certify that all lawful claims for materials, rental of equipment, tools machinery, services and labor used in connection with the construction of the above project, whether by subcontractor or claimant in person, have been duly discharged.

The undersigned, for the total consideration of \_\_\_\_\_Dollars (\$\_\_\_\_\_) as set out in the final pay estimate, as full and complete payment under the terms of the contract, hereby waives and relinquishes any and all further claims or right of lien under, in connection with, or as a result of the above described project. The undersigned further agrees to indemnify and save harmless the Town of Carefree against any and all liens, claims of liens, suits, action, damages, charges and expenses whatsoever, which said TOWN may suffer arising out of the failure of the undersigned to pay for all labor performances and materials furnished for the performance of said project construction items and/or services.

Signed and dated this \_\_\_\_\_ day of \_\_\_\_\_ 2023.

\_\_\_\_\_  
CONTRACTOR

\_\_\_\_\_  
BY:

STATE OF ARIZONA                    )  
) ss

COUNTY OF MARICOPA )

The foregoing instrument was subscribed and sworn to before me this \_\_\_\_\_ day of

\_\_\_\_\_, 2023.

\_\_\_\_\_  
Notary Public

My Commission expires:



# MAPPING OF STREET LOCATIONS APPENDIX A

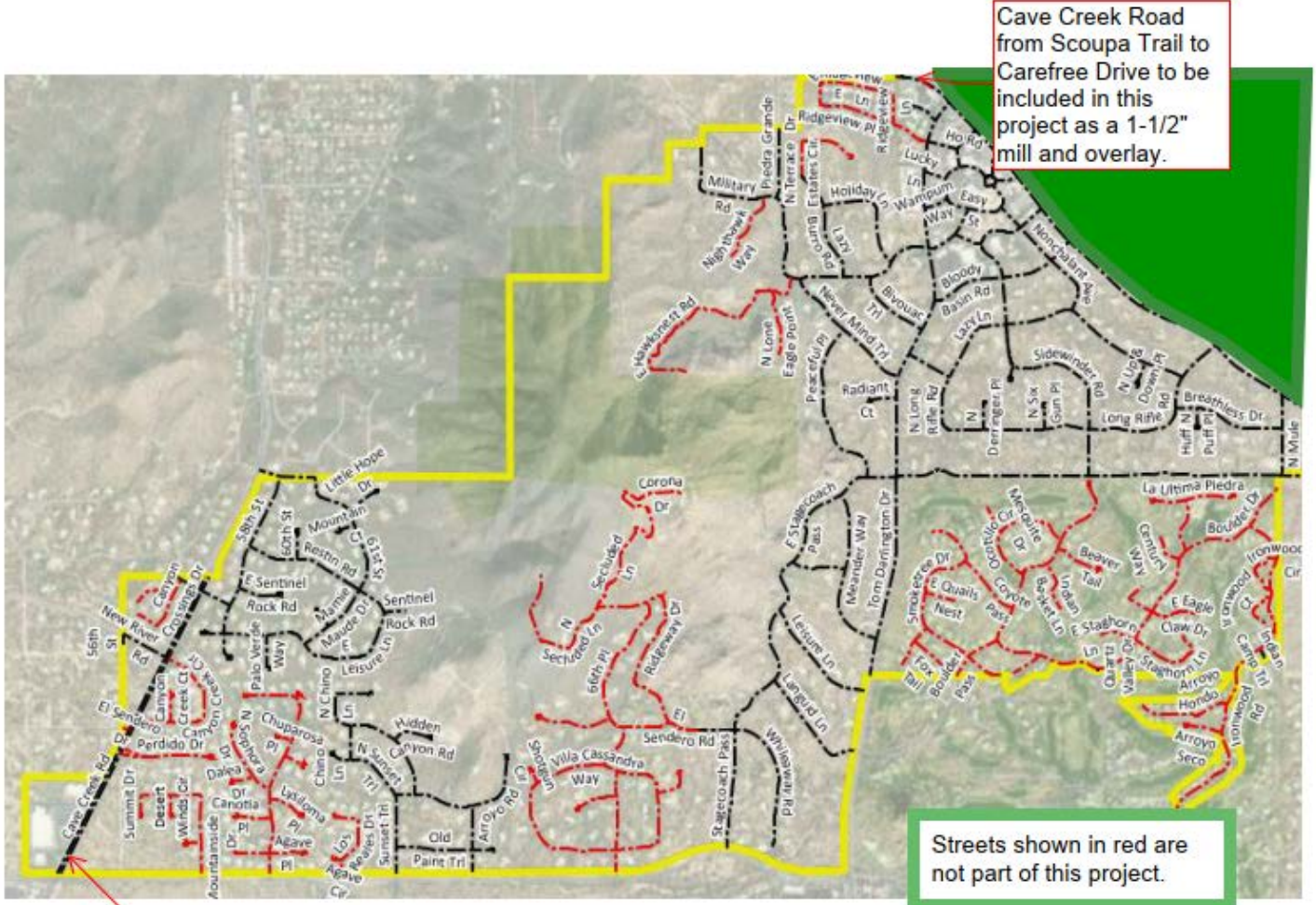

Cave Creek Road from Scoupa Trail to Carefree Drive to be included in this project as a 1-1/2" mill and overlay.

Streets shown in red are not part of this project.

Cave Creek Road (from Carefree Hwy to the Town Limits) to be reconstructed as a 1-1/2" mill and overlay NB. SB will consist of a fog coat.

NTS